

Cell Structure and Function

By

ARI WIBOWO. S.Pt., M.Si & SUHARDI. S.Pt., MP.

CLASS OF ANIMALS ANATOMY AND PHYSIOLOGY
2014

Cells

- Smallest living unit
- Most are microscopic



Discovery of Cells

- Robert Hooke (mid-1600s)
 - Observed sliver of cork
 - Saw “row of empty boxes”
 - Coined the term cell



Cell theory

- (1839)Theodor Schwann & Matthias Schleiden
“ all living things are made of cells”
- (50 yrs. later) Rudolf Virchow
“all cells come from cells”



Principles of Cell Theory

- All living things are made of cells
- Smallest living unit of structure and function of all organisms is the cell
- All cells arise from preexisting cells
(this principle discarded the idea of spontaneous generation)

Cell Size

Typical plant cell
10–100 μm

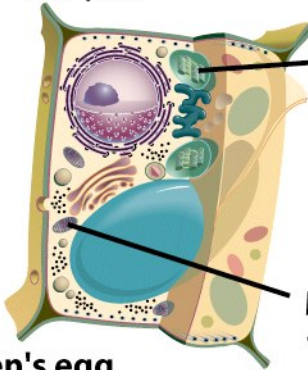

Chloroplast
2–10 μm

Mitochondrion
1–5 μm

Trypanosoma (protozoan)
25 μm long



Chlamydomonas
(green alga)
5–6 μm



HIV (AIDS virus)
100 nm

Poliovirus
30 nm



DNA molecule
2 nm diameter



Hen's egg
65 mm



Human red
blood cell
7–8 μm diameter



T4 bacteriophage
225 nm long



Escherichia coli
(bacterium)
1–5 μm long

Tobacco mosaic virus
300 nm long



Unaided vision

Light microscopes (down to 200 nm)

Electron microscopes (down to 0.5 nm)

1 mm 100 μm 10 μm 1 μm 100 nm 10 nm 1 nm 0.5 nm

Cells Have Large Surface Area-to-Volume Ratio

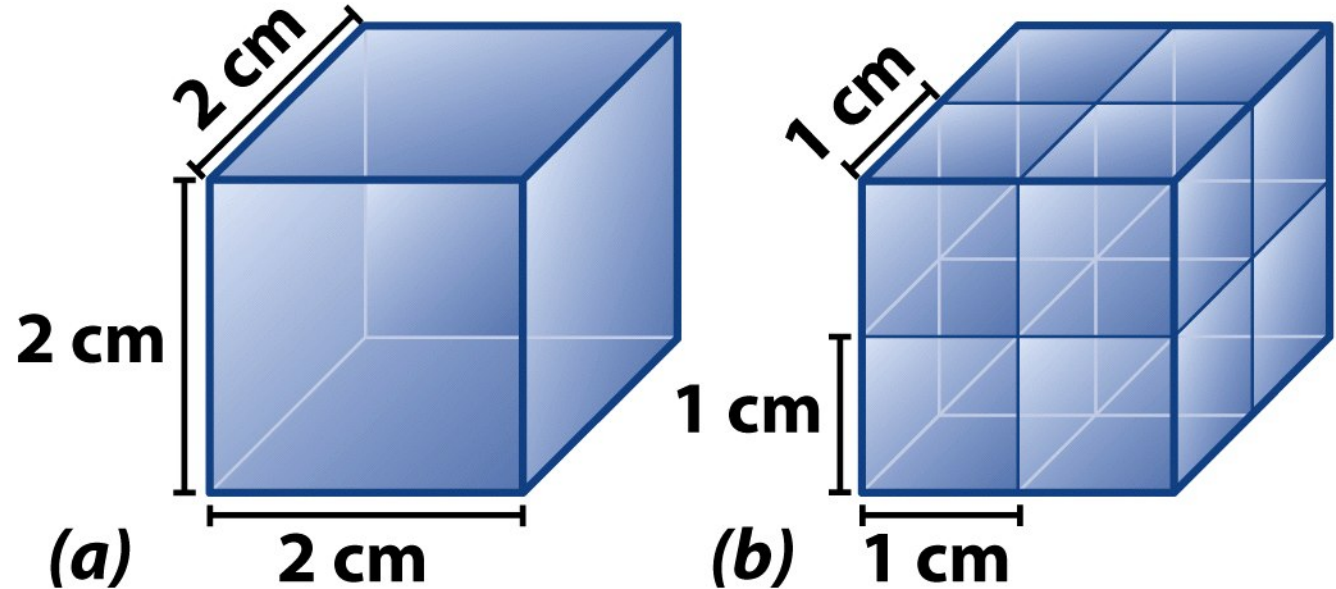

Number of cells	1	8
Total surface area	24 cm ²	48 cm ²
Total volume	8 cm ³	8 cm ³
Surface area/volume	24/8 = 3:1	48/8 = 6:1

Characteristics of All Cells

- A surrounding membrane
- Protoplasm – cell contents in thick fluid
- Organelles – structures for cell function
- Control center with DNA

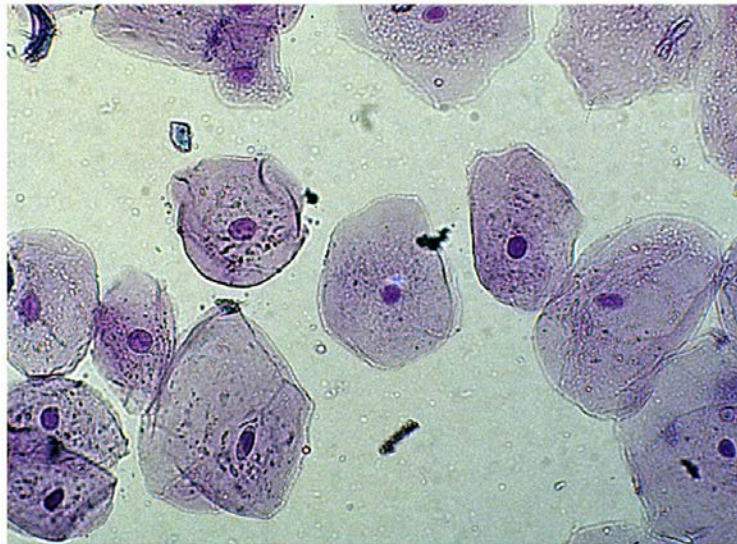

Cell Types

- Prokaryotic
- Eukaryotic



Prokaryotic Cells

- First cell type on earth
- Cell type of Bacteria and Archaea

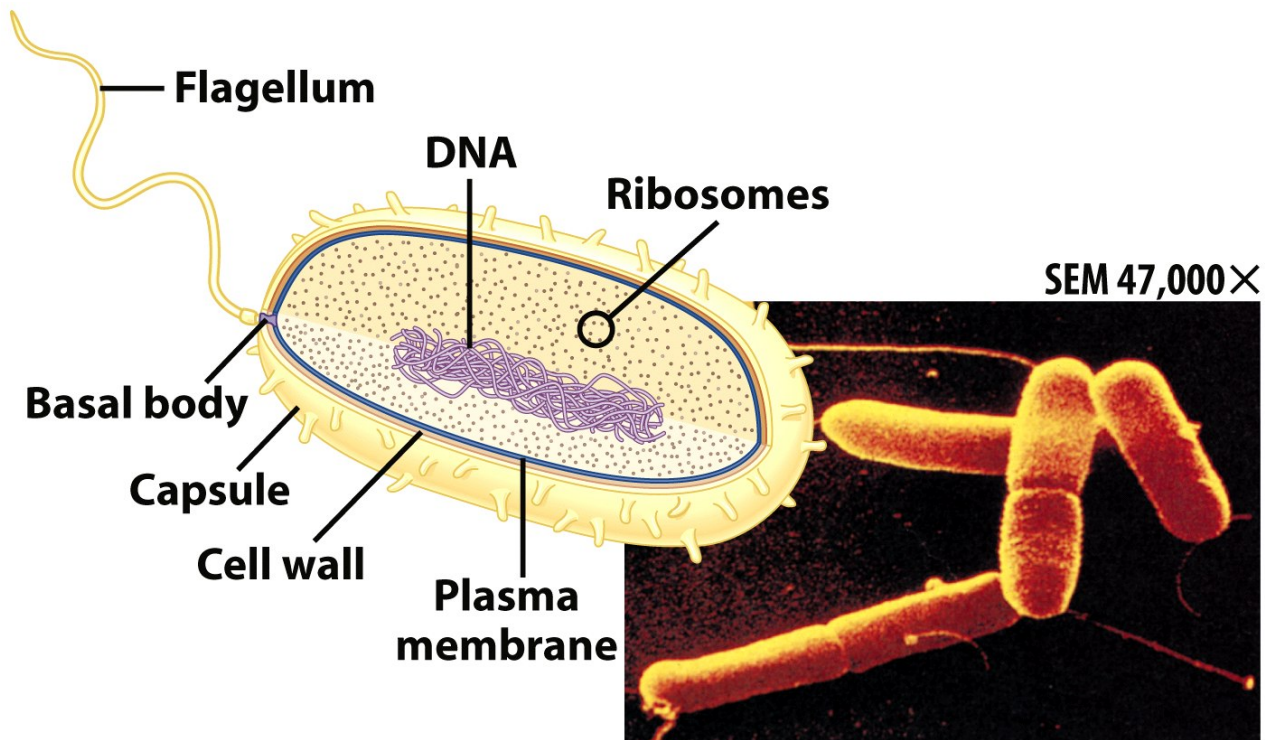

Prokaryotic Cells

- No membrane bound nucleus
- Nucleoid = region of DNA concentration
- Organelles not bound by membranes

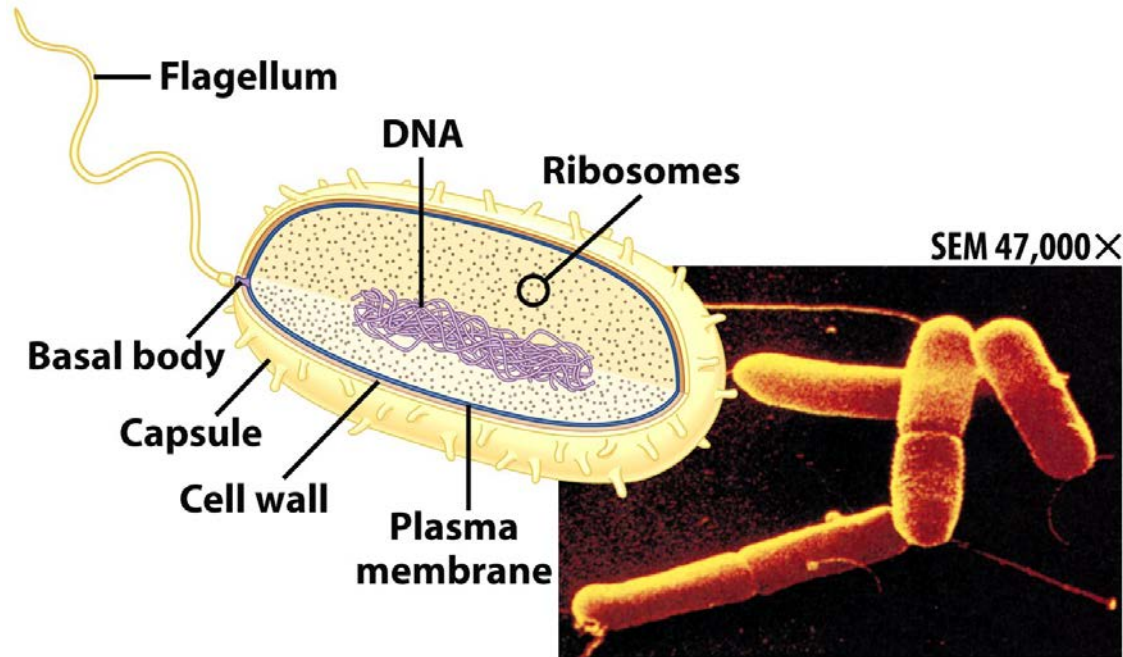

Eukaryotic Cells

- Nucleus bound by membrane
- Include fungi, protists, plant, and animal cells
- Possess many organelles

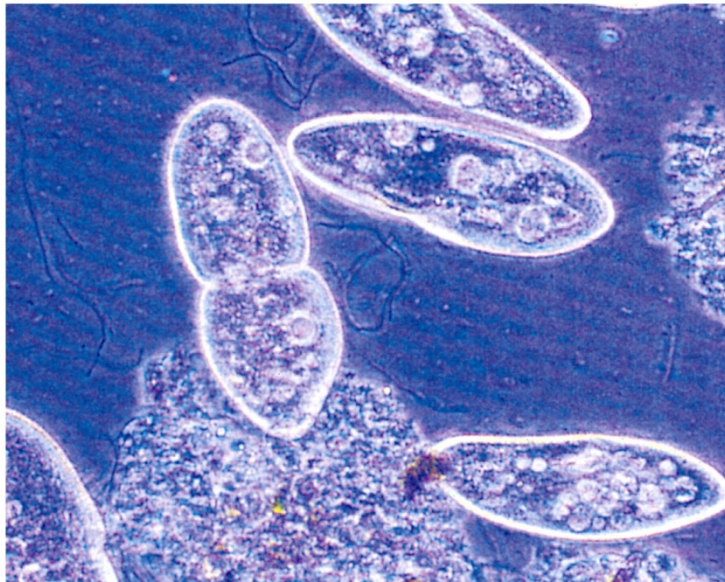

Protozoan

Representative Animal Cell

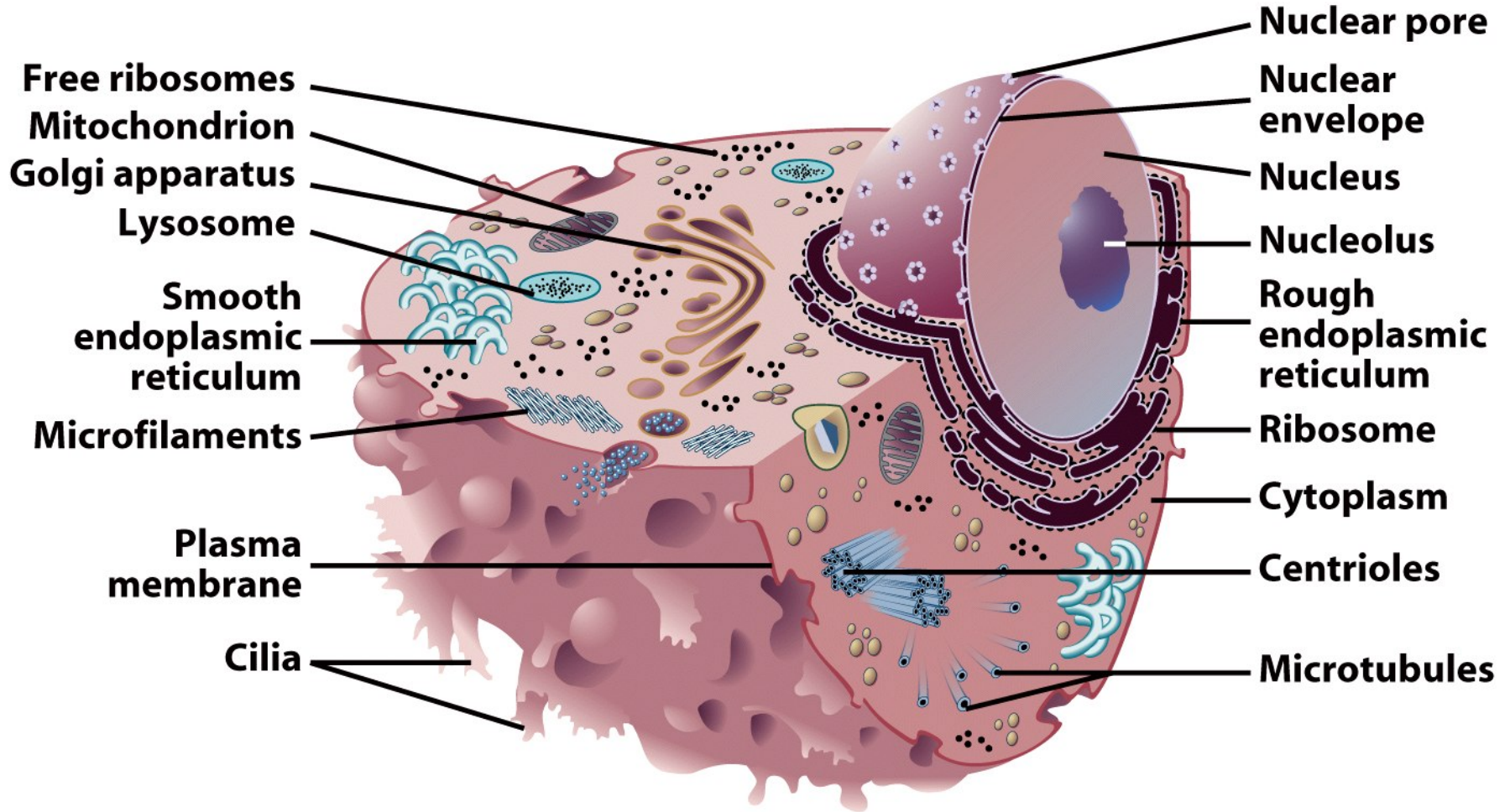

Representative Plant Cell

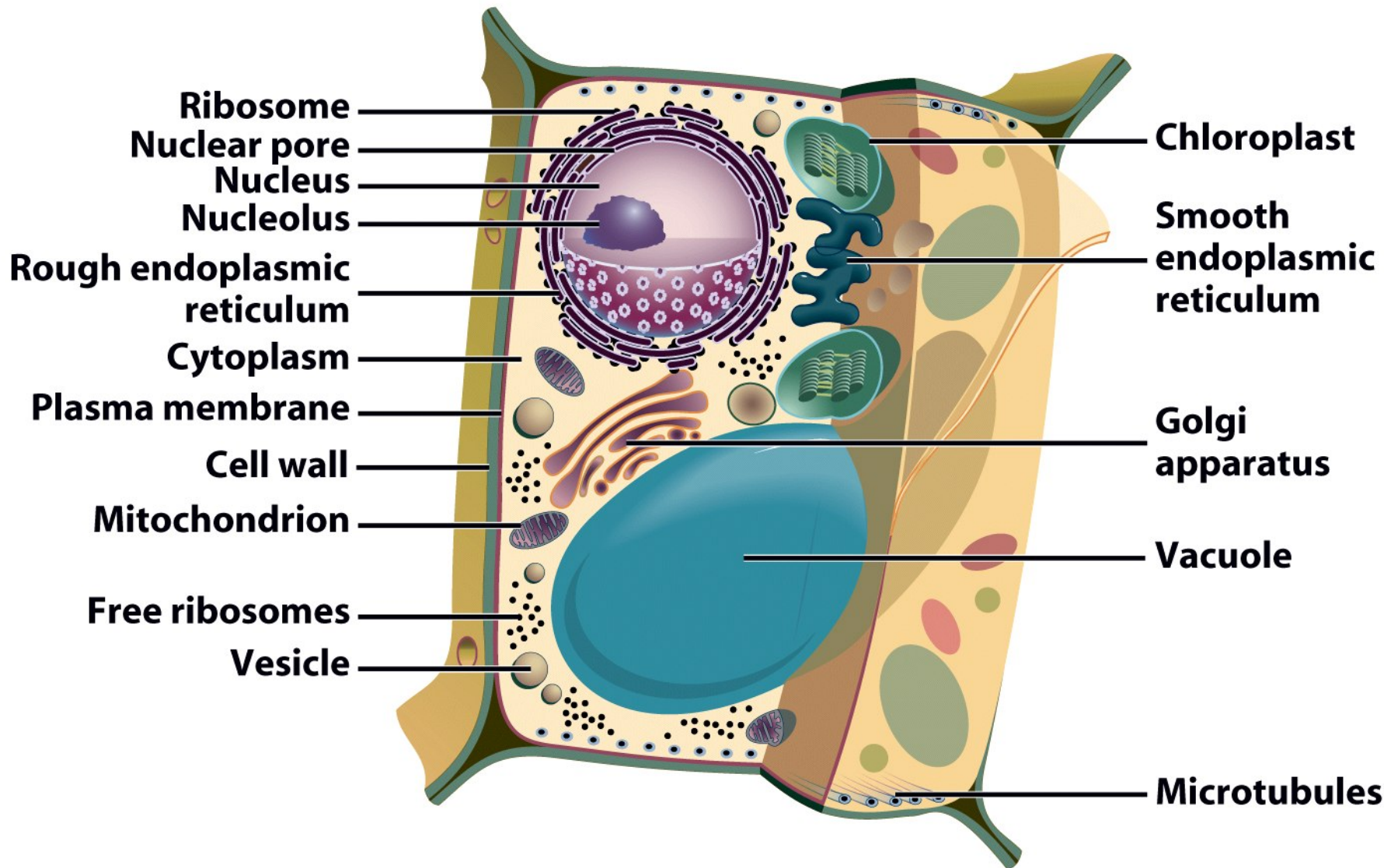

Organelles

- Cellular machinery
- Two general kinds
 - Derived from membranes
 - Bacteria-like organelles

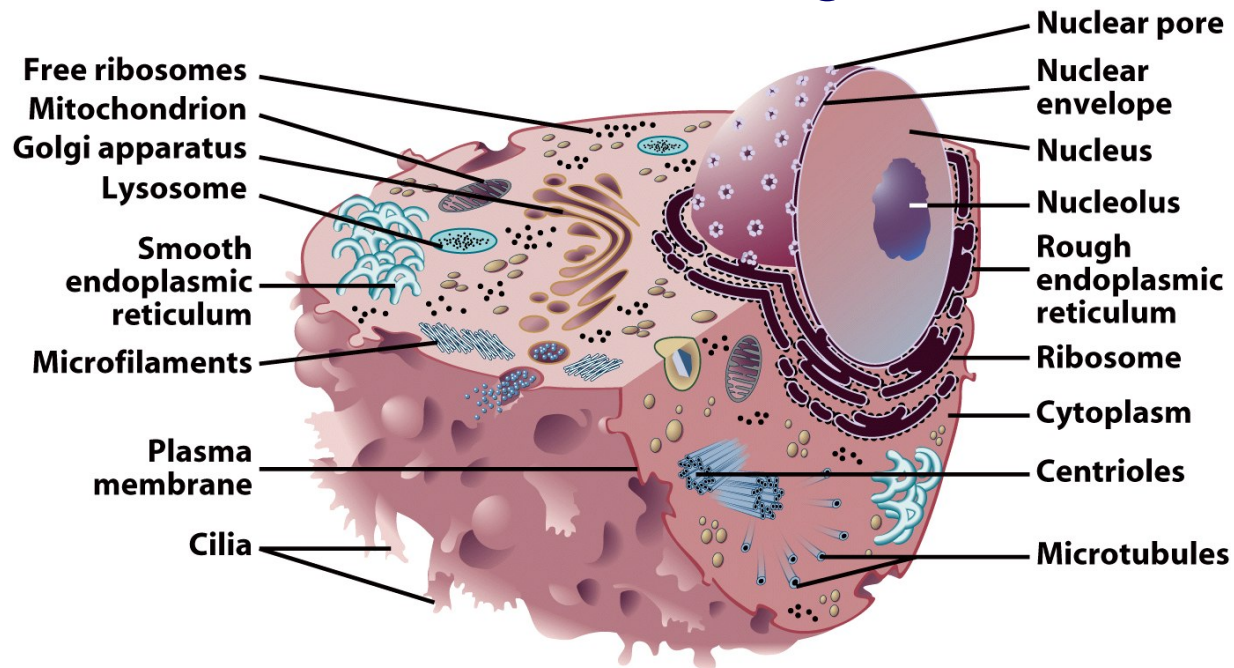

Bacteria-Like Organelles

- Derived from symbiotic bacteria
- Ancient association
- Endosymbiotic theory
 - Evolution of modern cells from cells & symbiotic bacteria

Plasma Membrane

- Contains cell contents
- Double layer of phospholipids & proteins

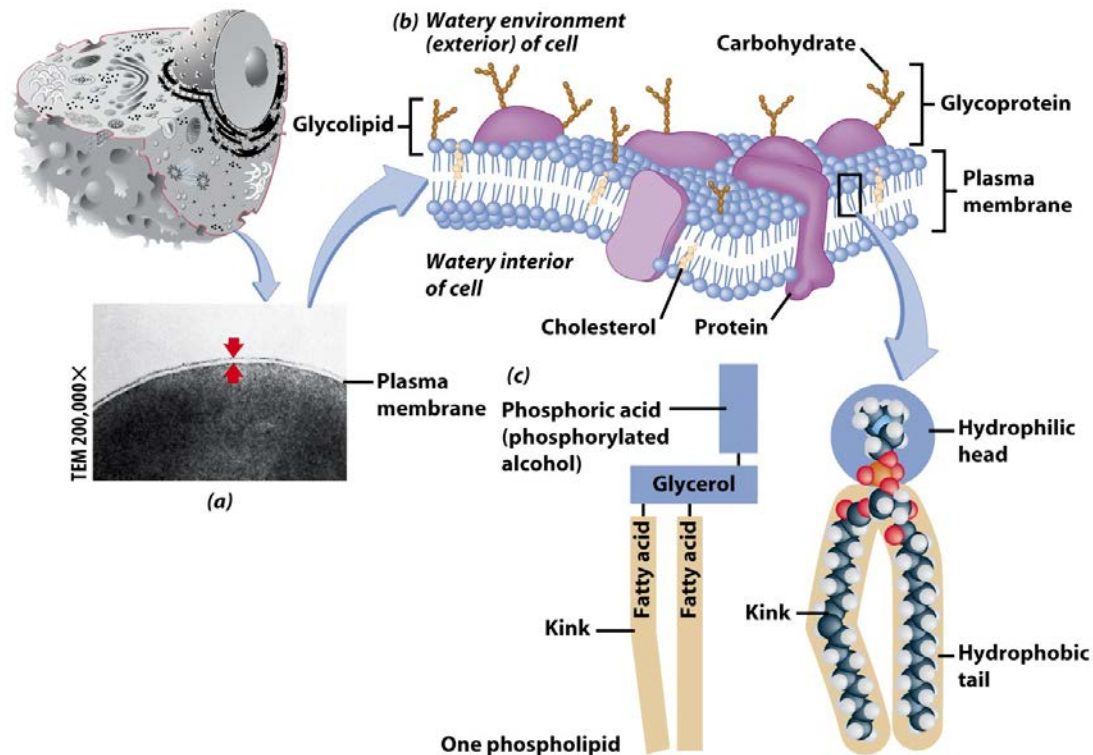

Phospholipids

- **Polar**
 - Hydrophylic head
 - Hydrophobic tail
- **Interacts with water**

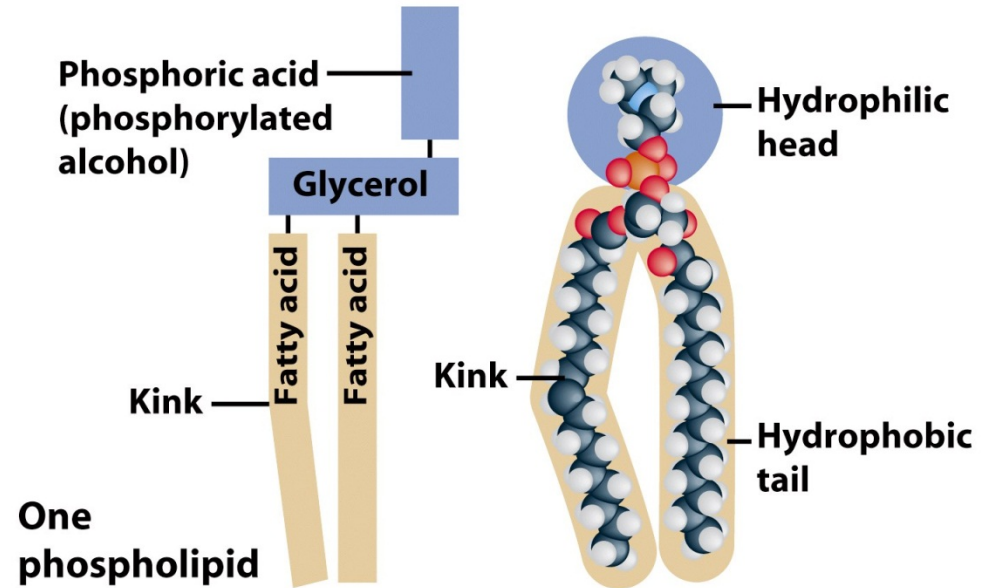

Movement Across the Plasma Membrane

- A few molecules move freely
 - Water, Carbon dioxide, Ammonia, Oxygen
- Carrier proteins transport some molecules
 - Proteins embedded in lipid bilayer
 - Fluid mosaic model – describes fluid nature of a lipid bilayer with proteins

(a)
Small uncharged
molecules

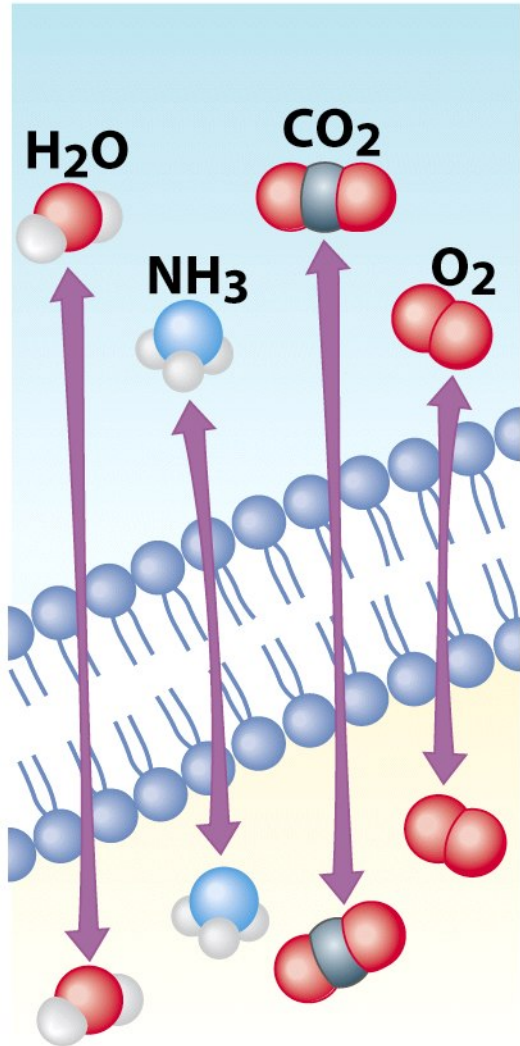

(b)
Lipid-soluble
substances

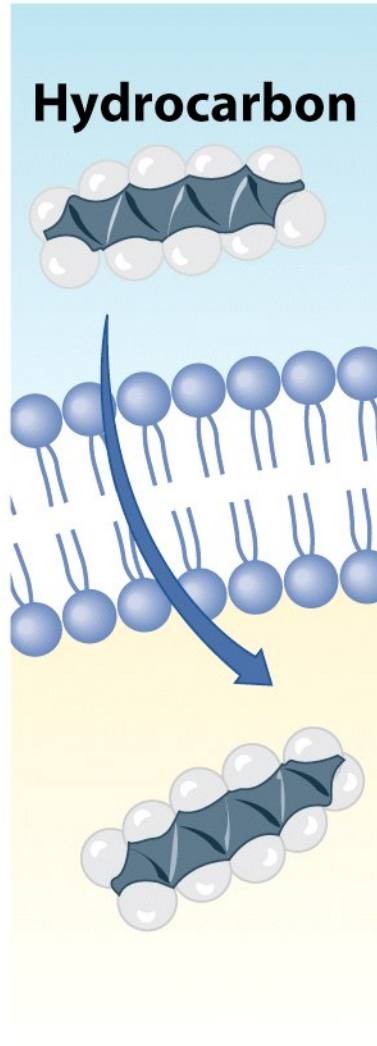

(c)
Water-soluble
substances

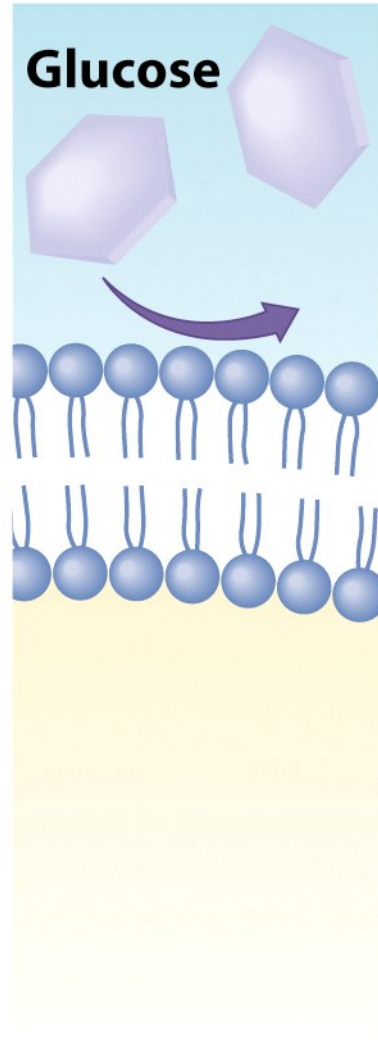

(d)
Ions

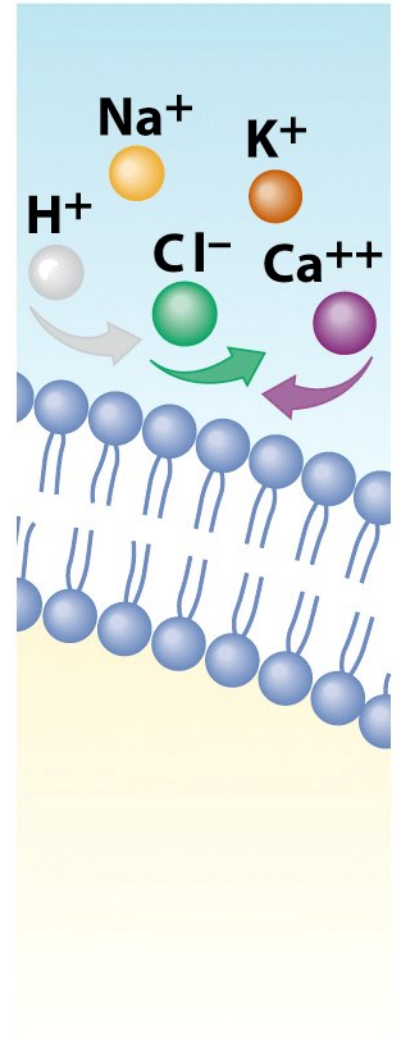

Membrane Proteins

1. Channels or transporters
 - Move molecules in one direction
2. Receptors
 - Recognize certain chemicals

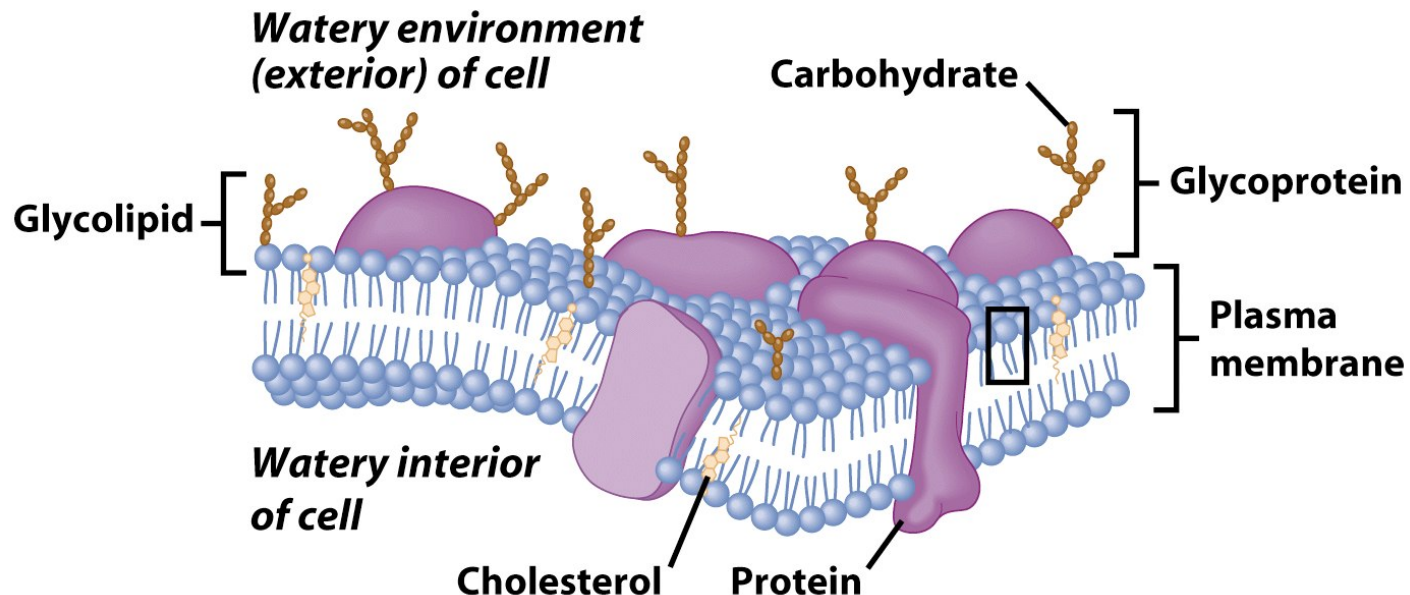

Membrane Proteins

3. Glycoproteins

- Identify cell type

4. Enzymes

- Catalyze production of substances

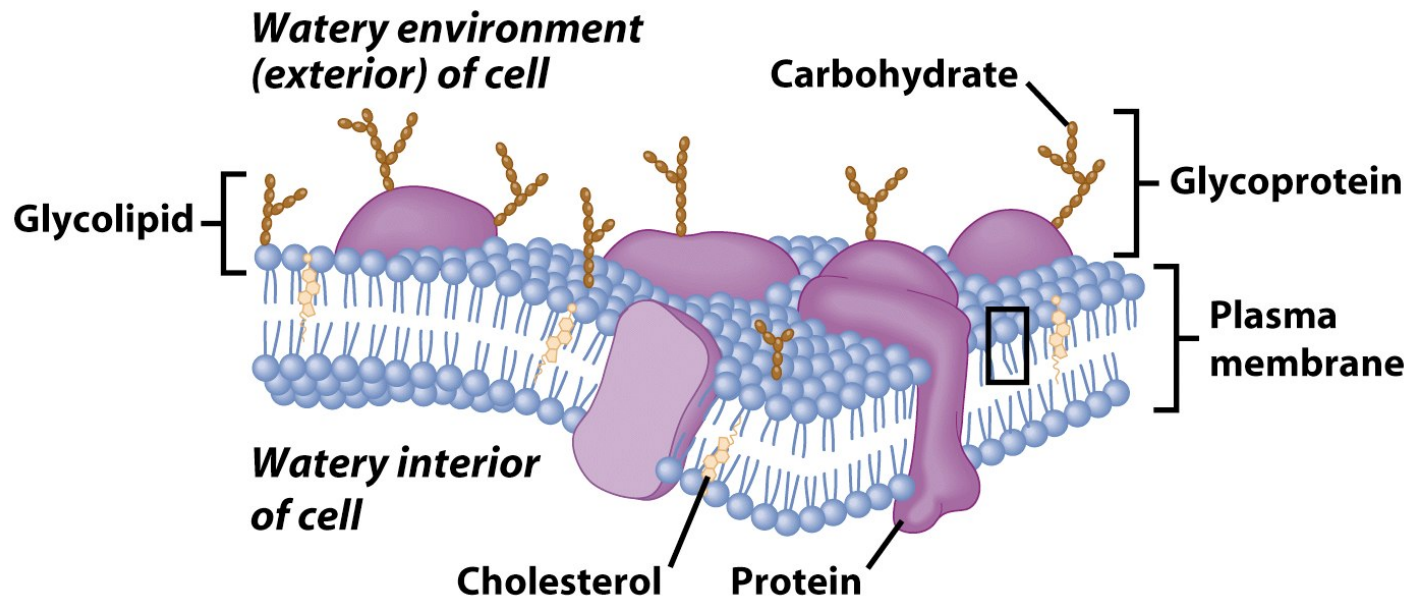

Cell Walls

- Found in plants, fungi, & many protists
- Surrounds plasma membrane



Cell Wall Differences

- Plants – mostly cellulose
- Fungi – contain chitin



Cytoplasm

- Viscous fluid containing organelles
- components of cytoplasm
 - Interconnected filaments & fibers
 - Fluid = cytosol
 - Organelles (not nucleus)
 - storage substances

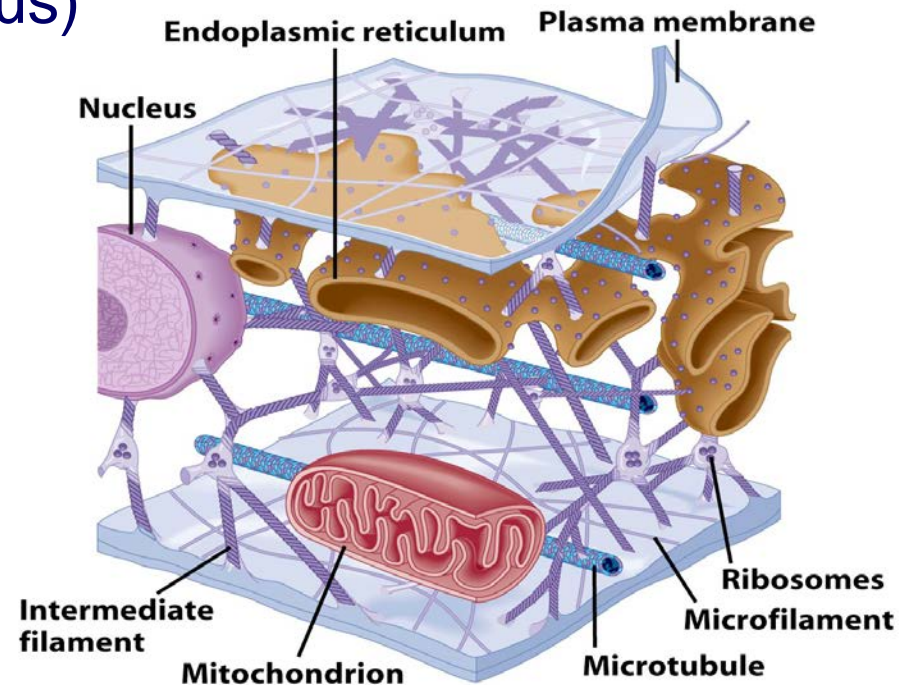

Cytoskeleton

- Filaments & fibers
- Made of 3 fiber types
 - Microfilaments
 - Microtubules
 - Intermediate filaments
- 3 functions:
 - mechanical support
 - anchor organelles
 - help move substances

(a) Microfilament



(b) Microtubule

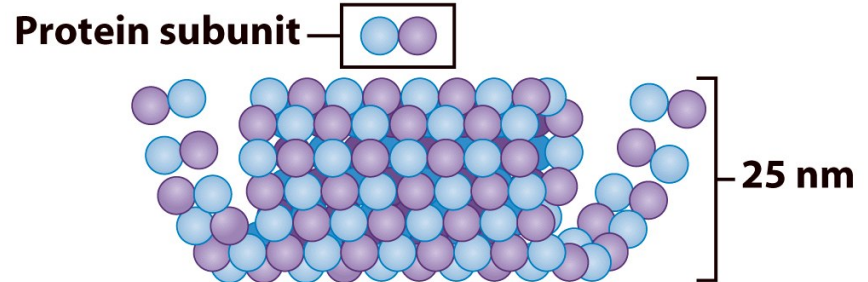

(c) Intermediate filament

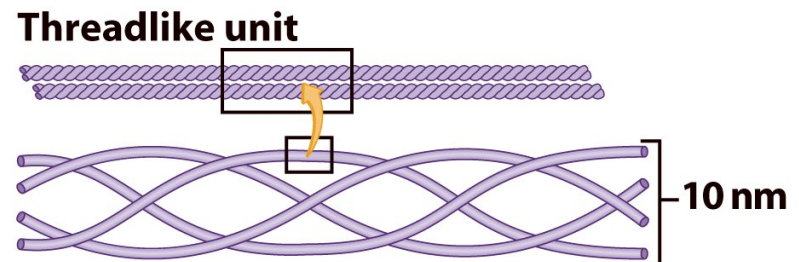

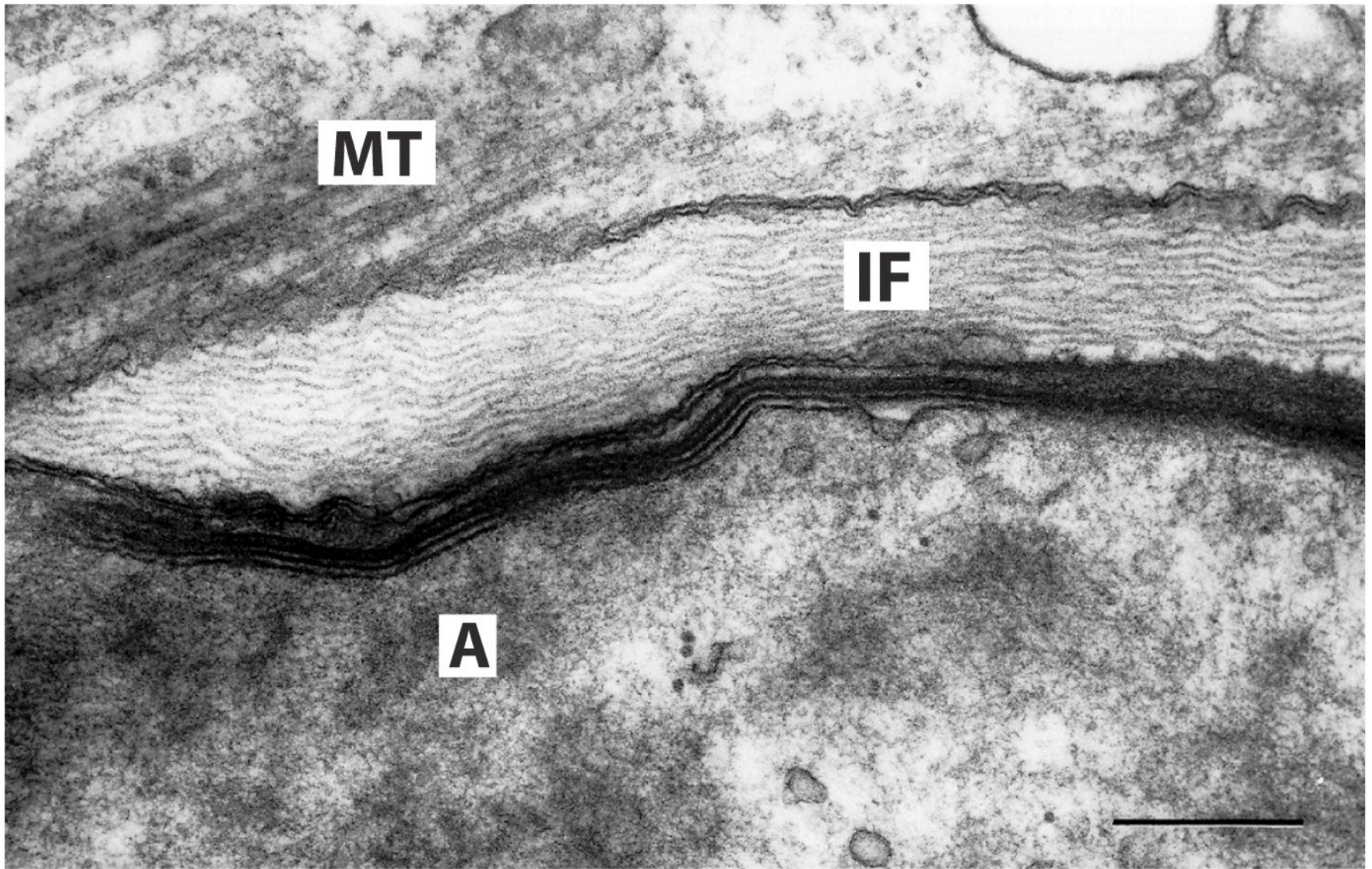

A = actin, IF = intermediate filament, MT = microtubule

Cilia & Flagella

- Provide motility
- Cilia
 - Short
 - Used to move substances outside human cells
- Flagella
 - Whip-like extensions
 - Found on sperm cells
- Basal bodies like centrioles



Cilia & Flagella Structure

- Bundles of microtubules
- With plasma membrane

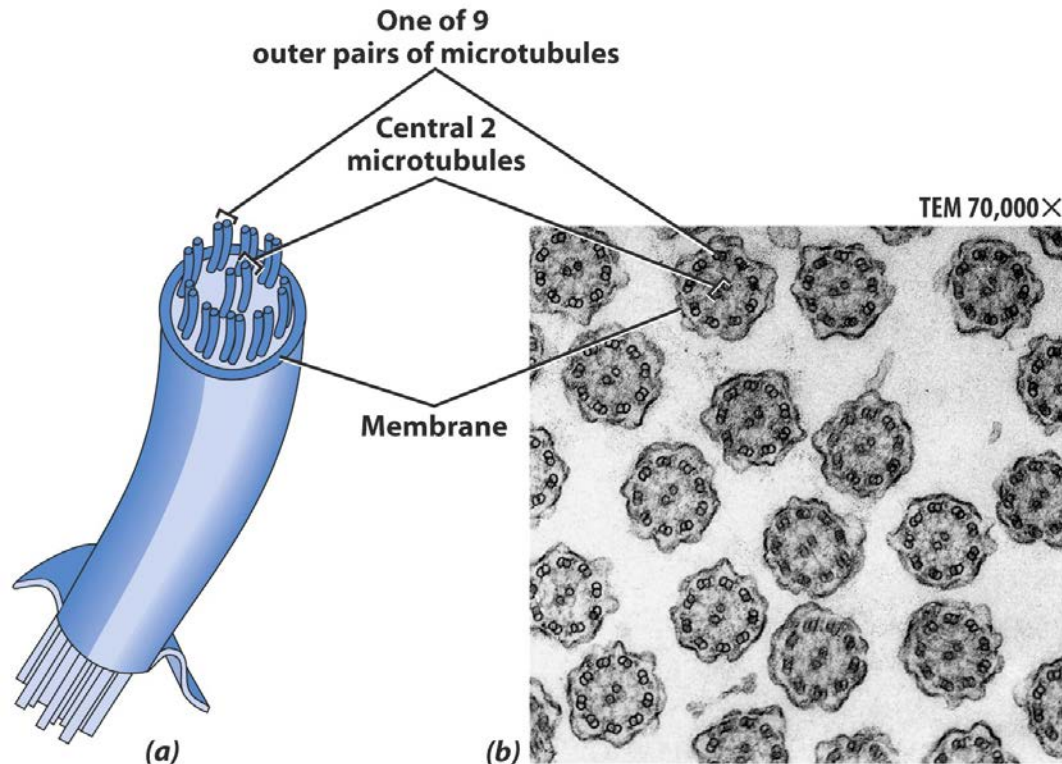

Centrioles

- Pairs of microtubular structures
- Play a role in cell division



Membranous Organelles

- Functional components within cytoplasm
- Bound by membranes

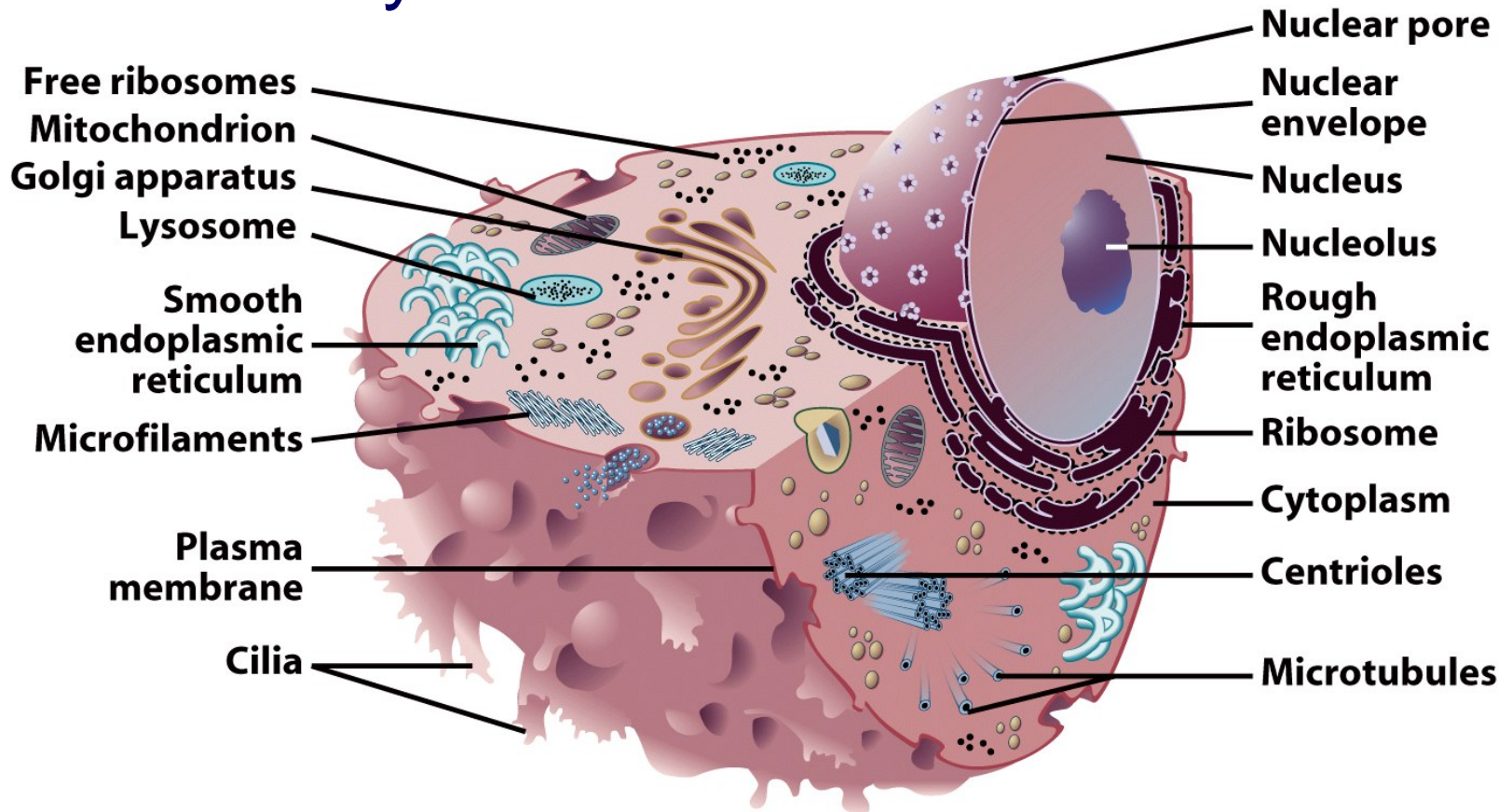

Nucleus

- Control center of cell
- Double membrane
- Contains
 - Chromosomes
 - Nucleolus

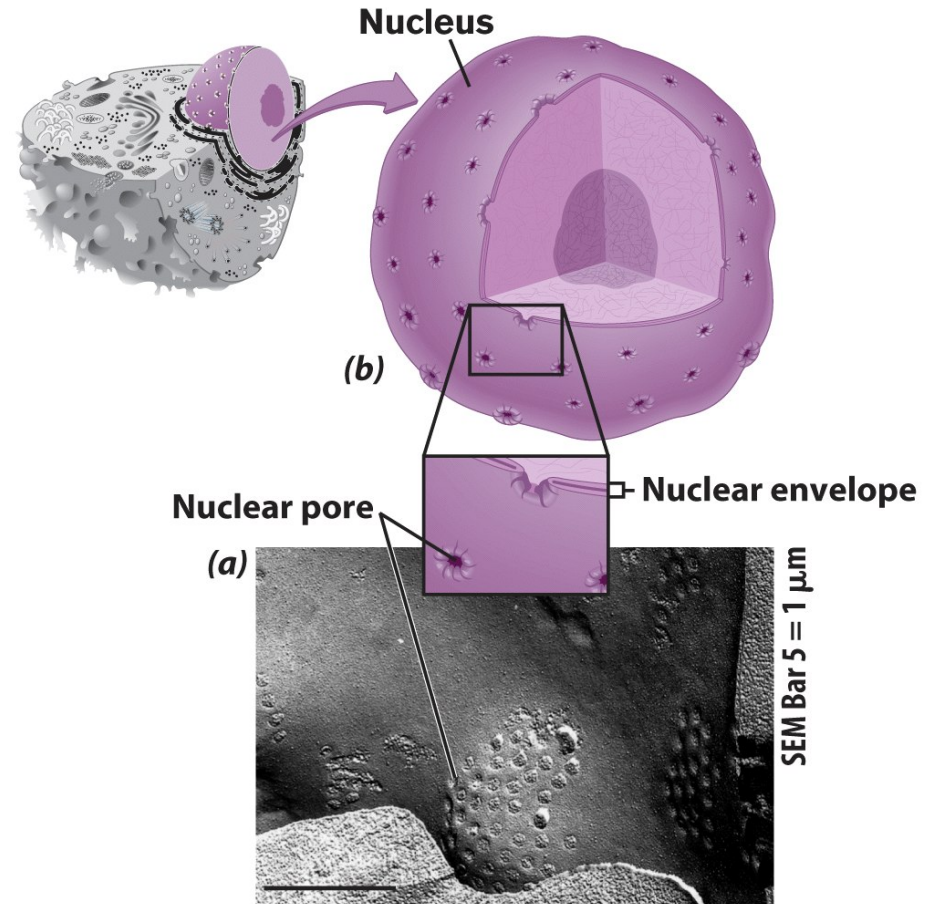

Nuclear Envelope

- Separates nucleus from rest of cell
- Double membrane
- Has pores

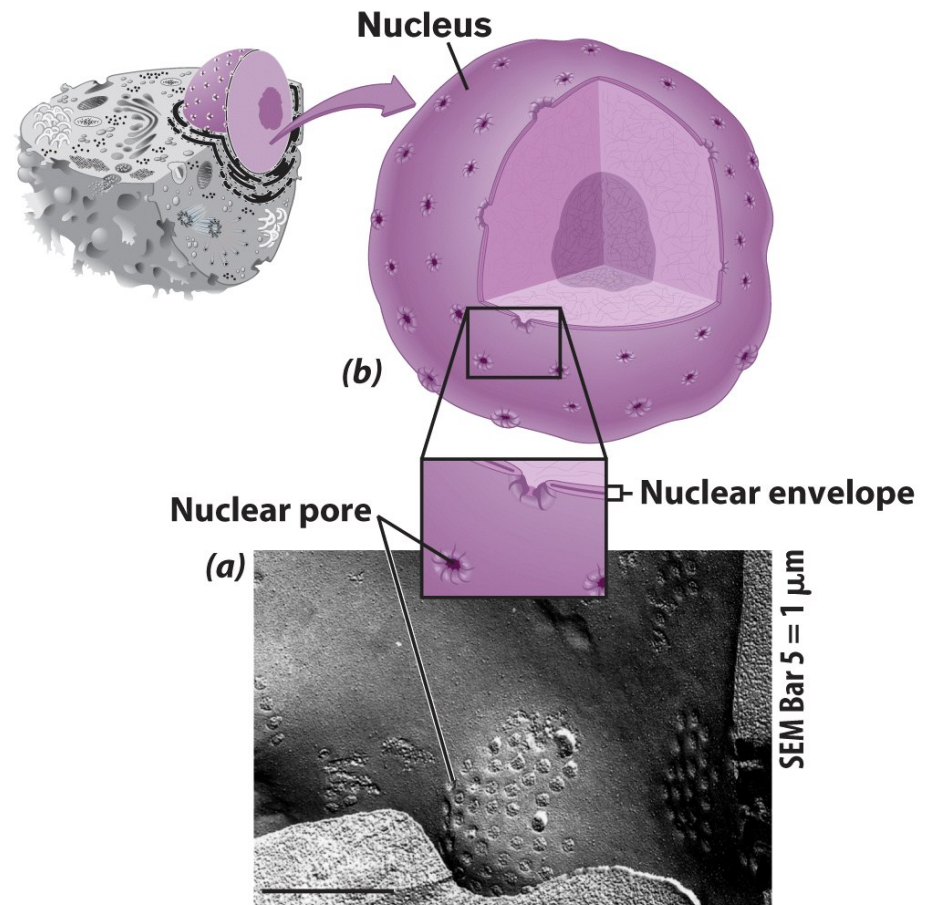

DNA

- Hereditary material
- Chromosomes
 - DNA
 - Proteins
 - Form for cell division
- Chromatin



Nucleolus

- Most cells have 2 or more
- Directs synthesis of RNA
- Forms ribosomes

Nuclear membrane Nucleus Nucleolus

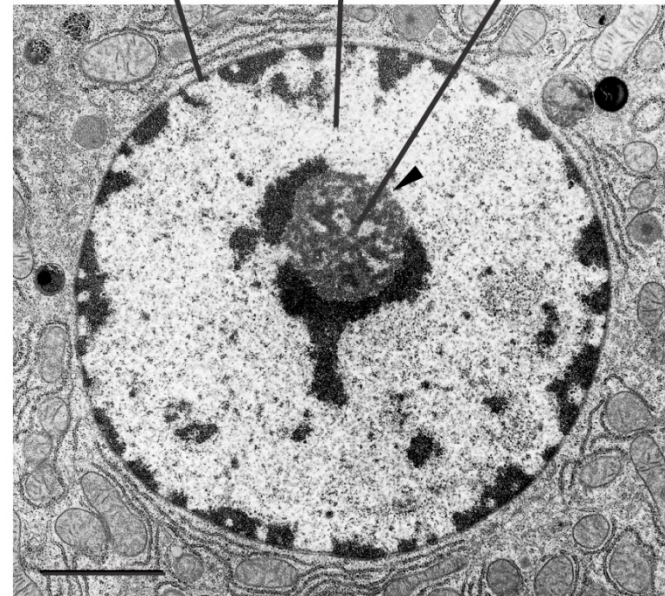

Endoplasmic Reticulum

- Helps move substances within cells
- Network of interconnected membranes
- Two types
 - Rough endoplasmic reticulum
 - Smooth endoplasmic reticulum

Rough Endoplasmic Reticulum

- Ribosomes attached to surface
 - Manufacture proteins
 - Not all ribosomes attached to rough ER
- May modify proteins from ribosomes

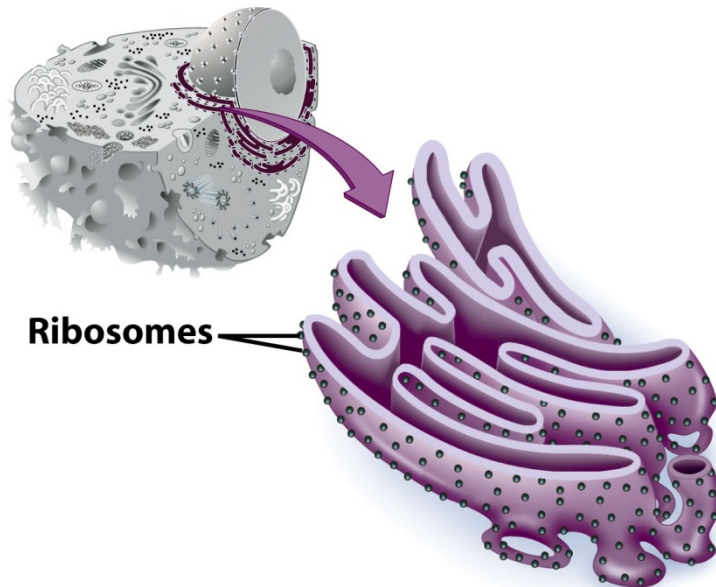

Smooth Endoplasmic Reticulum

- No attached ribosomes
- Has enzymes that help build molecules
 - Carbohydrates
 - Lipids

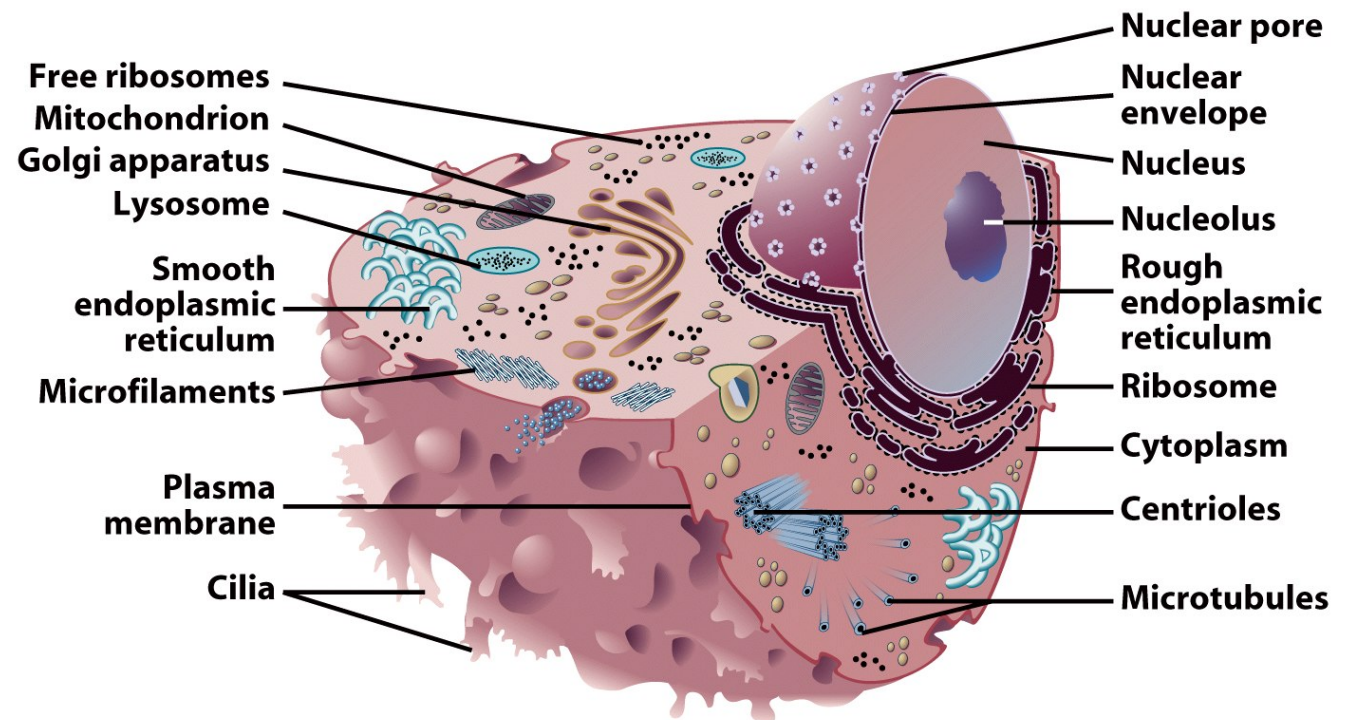

Golgi Apparatus

- Involved in synthesis of plant cell wall
- Packaging & shipping station of cell

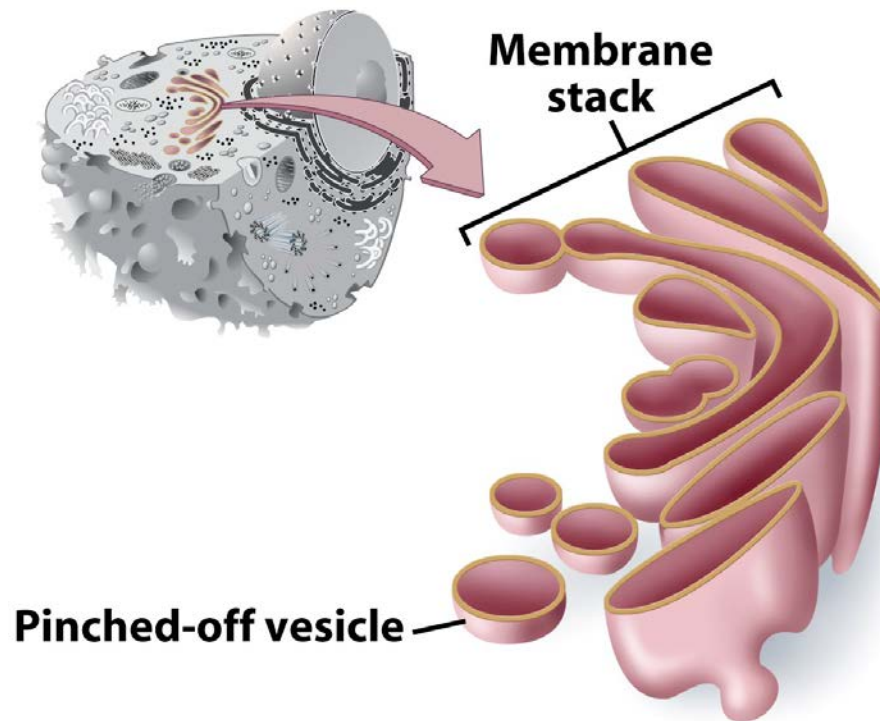

Golgi Apparatus Function

1. Molecules come in vesicles
2. Vesicles fuse with Golgi membrane
3. Molecules may be modified by Golgi

Golgi Apparatus Function (Continued)

4. Molecules pinched-off in separate vesicle
5. Vesicle leaves Golgi apparatus
6. Vesicles may combine with plasma membrane to secrete contents

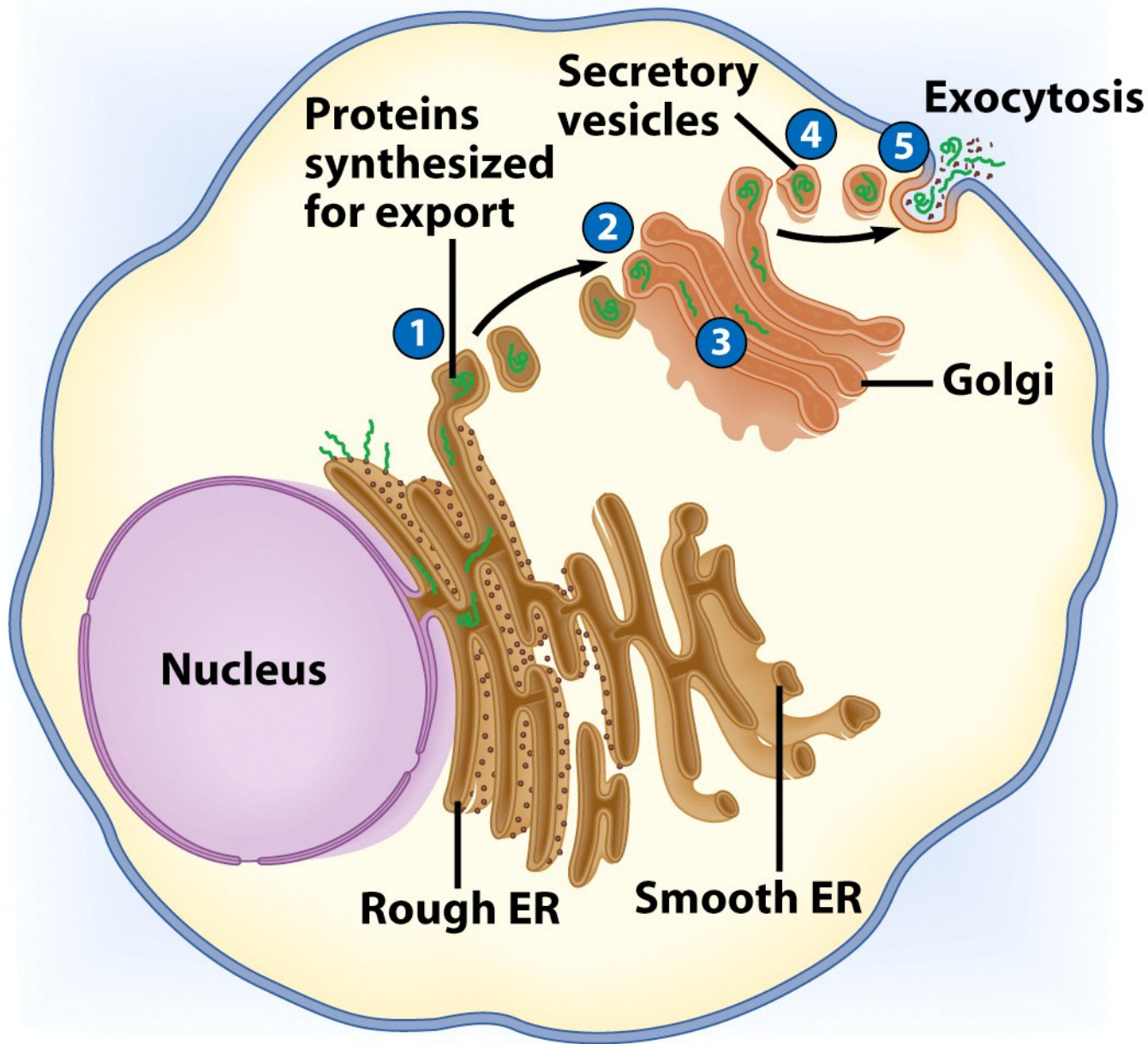

Lysosomes

- Contain digestive enzymes
- Functions
 - Aid in cell renewal
 - Break down old cell parts
 - Digests invaders

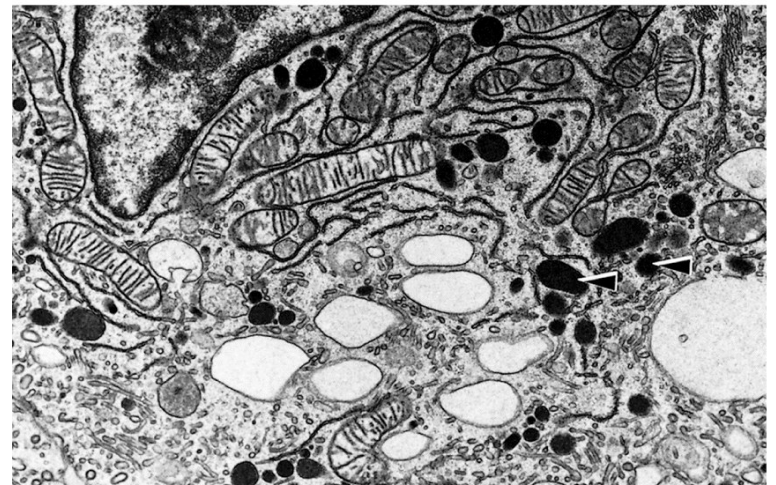
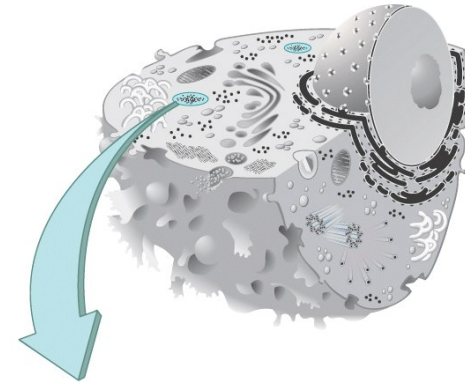

Vacuoles

- Membrane bound storage sacs
- More common in plants than animals
- Contents
 - Water
 - Food
 - wastes

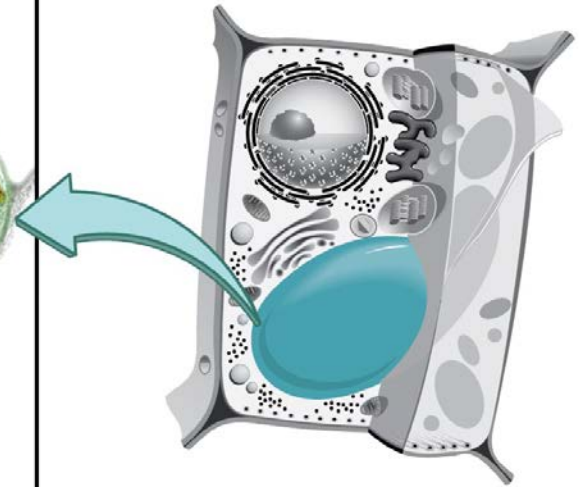
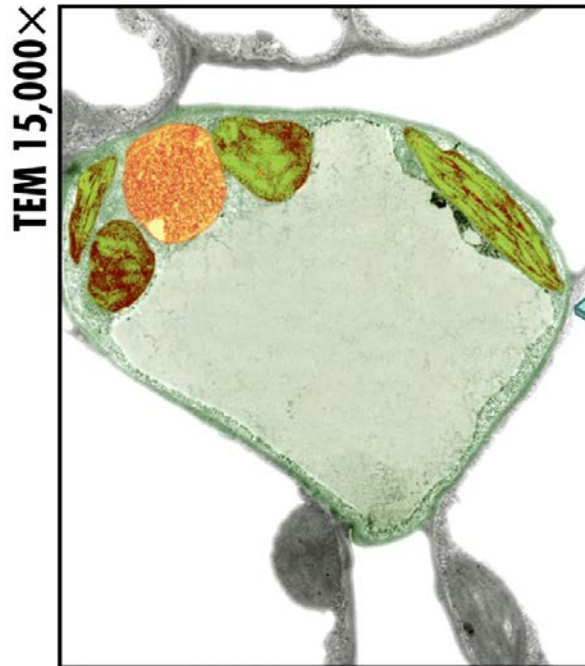

Bacteria-Like Organelles

- Release & store energy

- Types

- Mitochondria
(release energy)
- Chloroplasts
(store energy)

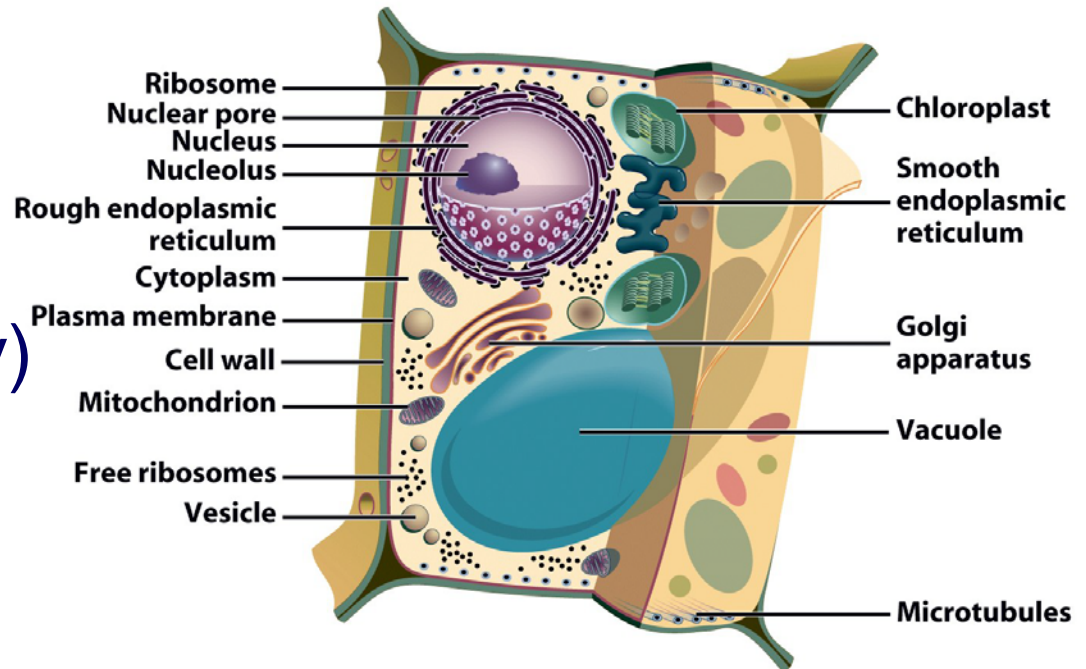

Mitochondria

- Have their own DNA
- Bound by double membrane

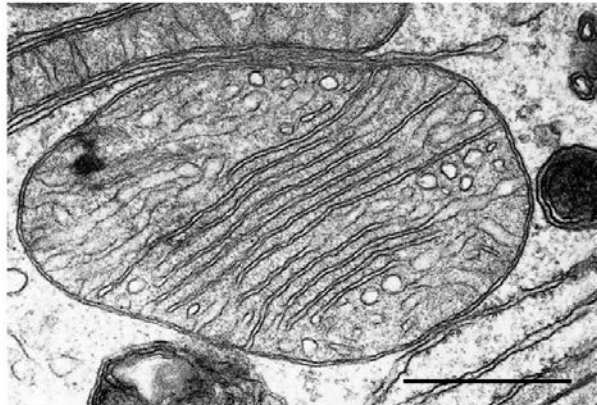
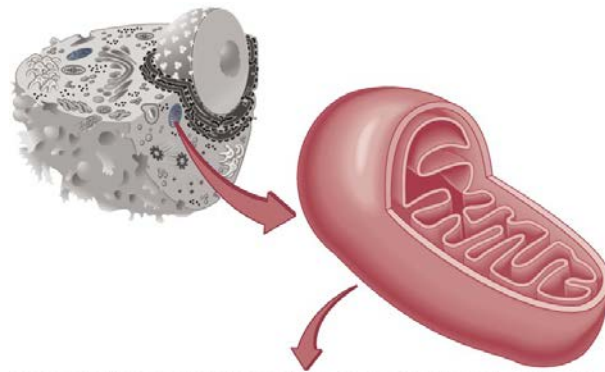

Mitochondria

- Break down fuel molecules (cellular respiration)
 - Glucose
 - Fatty acids
- Release energy
 - ATP

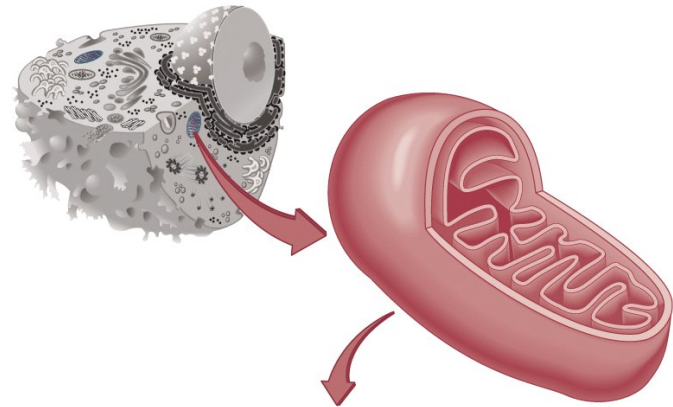

Chloroplasts

- Derived from photosynthetic bacteria
- Solar energy capturing organelle

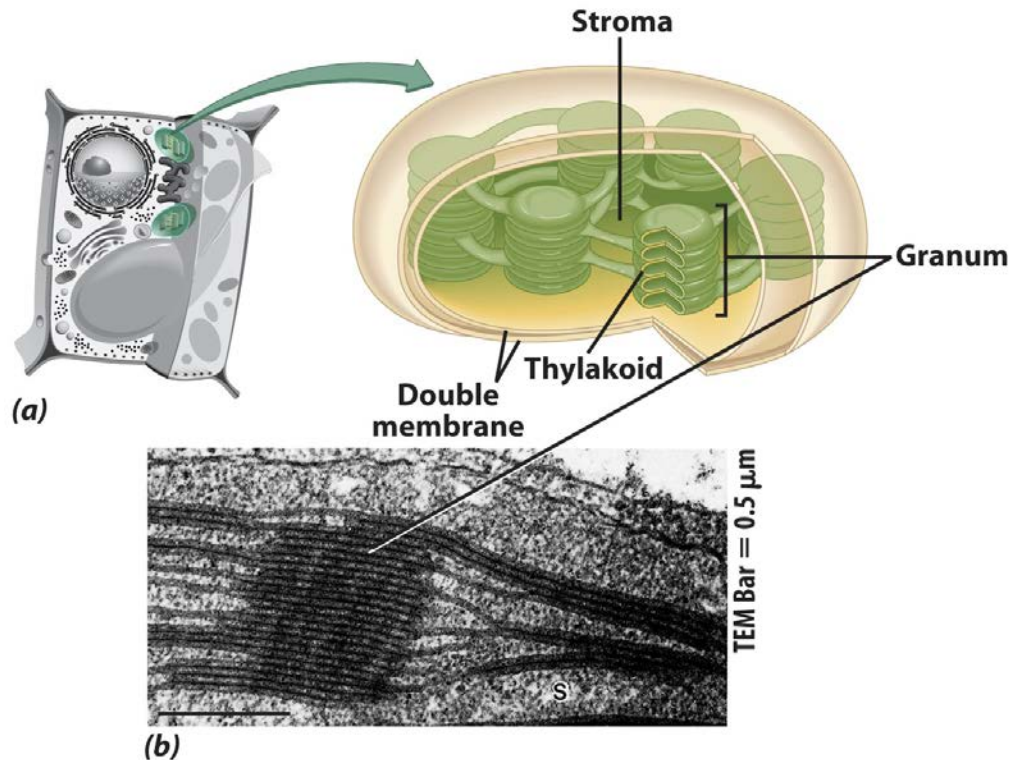

Photosynthesis

- Takes place in the chloroplast
- Makes cellular food – glucose

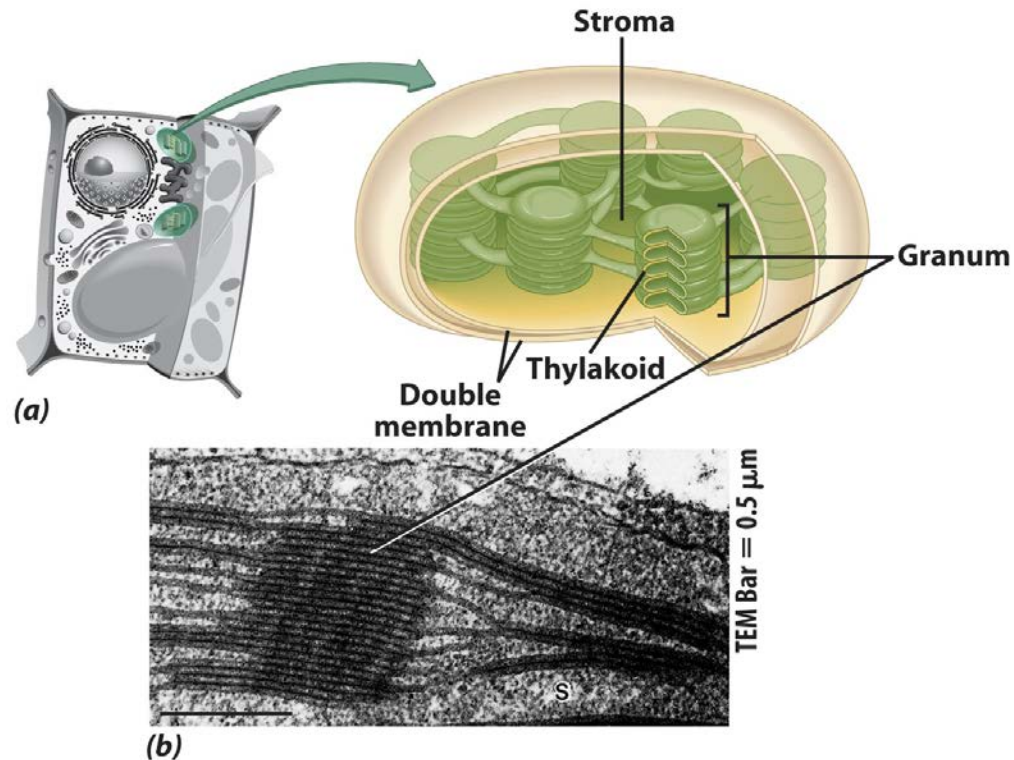

Review of Eukaryotic Cells

TABLE 5.1

Eukaryotic Cell Structures and Their Functions

Structure	Description	Function
Exterior Structures		
Cell wall	Outer layer of cellulose or chitin, or absent	Protection, support
Plasma membrane	Lipid bilayer in which proteins are embedded	Regulation of what passes in and out of cell, cell-to-cell recognition
Flagella (cilia)	Cellular extensions with 9 + 2 arrangement of pairs of microtubules	Motility or moving fluids over surfaces

Review of Eukaryotic Cells

TABLE 5.1

Eukaryotic Cell Structures and Their Functions

Structure	Description	Function
Interior Structures and Organelles		
Endoplasmic reticulum (ER)	Network of internal membranes	Formation of compartments and vesicles; modification and transport of proteins; synthesis of carbohydrates and lipids
Ribosomes	Small, complex assemblies of protein and RNA, often bound to ER	Sites of protein synthesis
Nucleus	Spherical structure bounded by a double membrane, site of chromosomes	Control center of cell
Chromosomes	Long threads of DNA associated with protein	Sites of hereditary information
Nucleolus	Site within nucleus of rRNA synthesis	Synthesis and assembly of ribosomes
Golgi apparatus	Stacks of flattened vesicles	Packaging of proteins for export from cell
Lysosomes	Membranous sacs containing digestive enzymes found in animal cells	Digestion of various molecules
Cytoskeleton	Network of protein filaments, fibers, and tubules	Structural support, cell movement
Mitochondria	Bacteria like elements with inner membrane highly folded	“Power plant” of the cell
Chloroplasts	Bacterial like elements with inner membrane forming sacs containing chlorophyll, found in plant cells and algae	Site of photosynthesis

TABLE 5.2**A Comparison of Bacterial, Animal, and Plant Cells**

	Bacterium	Animal	Plant
Exterior Structures			
Cell wall	Present (protein polysaccharide)	<i>Absent</i>	Present (cellulose)
Plasma membrane	Present	Present	Present
Flagella (cilia)	Sometimes present	Sometimes present	Sperm of a few species possess flagella
Interior Structures and Organelles			
Endoplasmic reticulum	<i>Absent</i>	Usually present	Usually present
Microtubules	<i>Absent</i>	Present	Present
Centrioles	<i>Absent</i>	Present	<i>Absent</i>
Golgi apparatus	<i>Absent</i>	Present	Present
Nucleus	<i>Absent</i>	Present	Present
Mitochondria	<i>Absent</i>	Present	Present
Chloroplasts	<i>Absent</i>	<i>Absent</i>	Present
Chromosomes	A single circle of naked DNA	Multiple units, DNA associated with protein	Multiple units, DNA associated with protein
Ribosomes	Present	Present	Present
Lysosomes	<i>Absent</i>	Present	Present
Vacuoles	<i>Absent</i>	<i>Absent</i> or small	Usually a large single vacuole in mature cell

Molecule Movement & Cells

- Passive Transport
- Active Transport
- Endocytosis
(phagocytosis & pinocytosis)
- Exocytosis

Passive Transport

- No energy required
- Move due to gradient
 - differences in concentration, pressure, charge
- Move to equalize gradient
 - High moves toward low

Types of Passive Transport

1. Diffusion

2. Osmosis

3. Facilitated diffusion

Diffusion

- Molecules move to equalize concentration

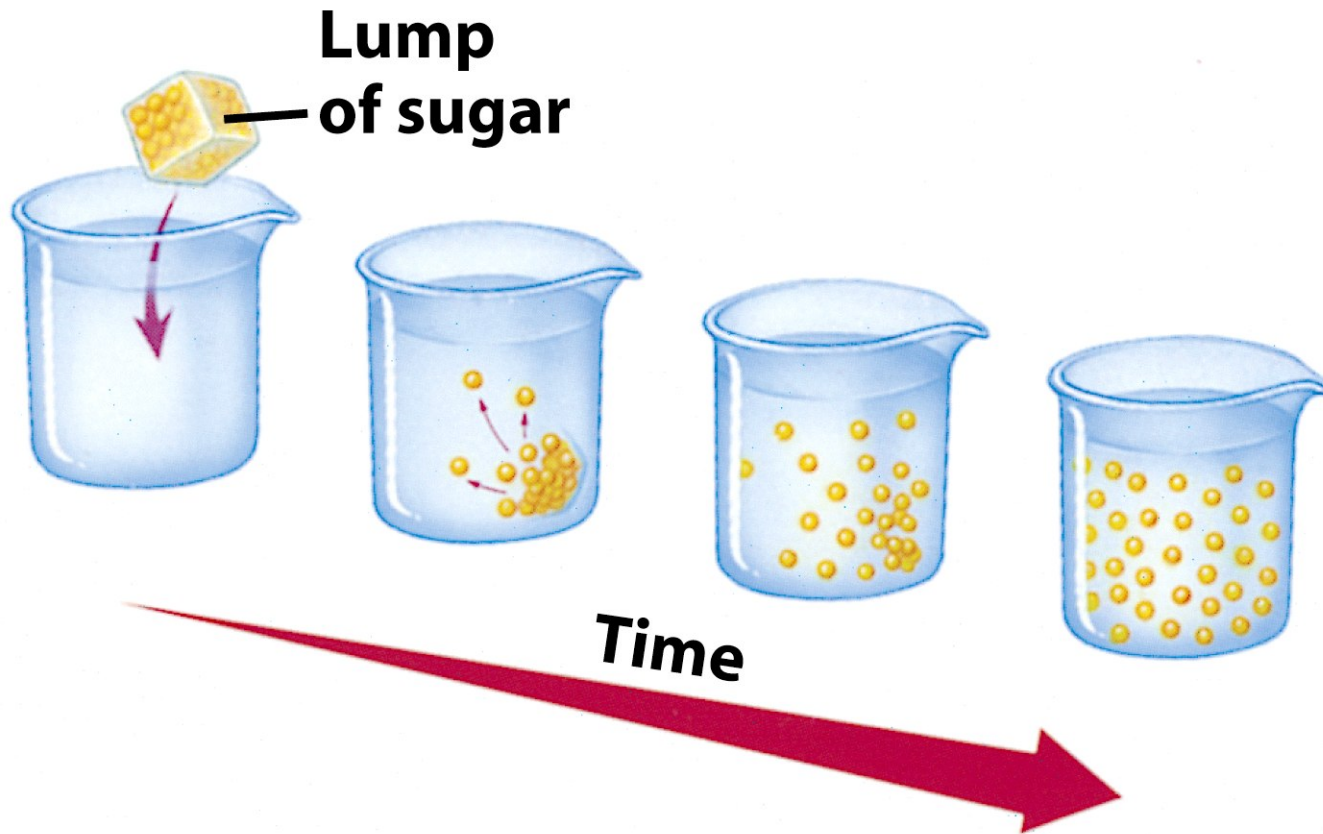

Osmosis

- Special form of diffusion
- Fluid flows from lower solute concentration
- Often involves movement of water
 - Into cell
 - Out of cell

Solution Differences & Cells

- solvent + solute = solution
- Hypotonic
 - Solutes in cell more than outside
 - Outside solvent will flow into cell
- Isotonic
 - Solutes equal inside & out of cell
- Hypertonic
 - Solutes greater outside cell
 - Fluid will flow out of cell

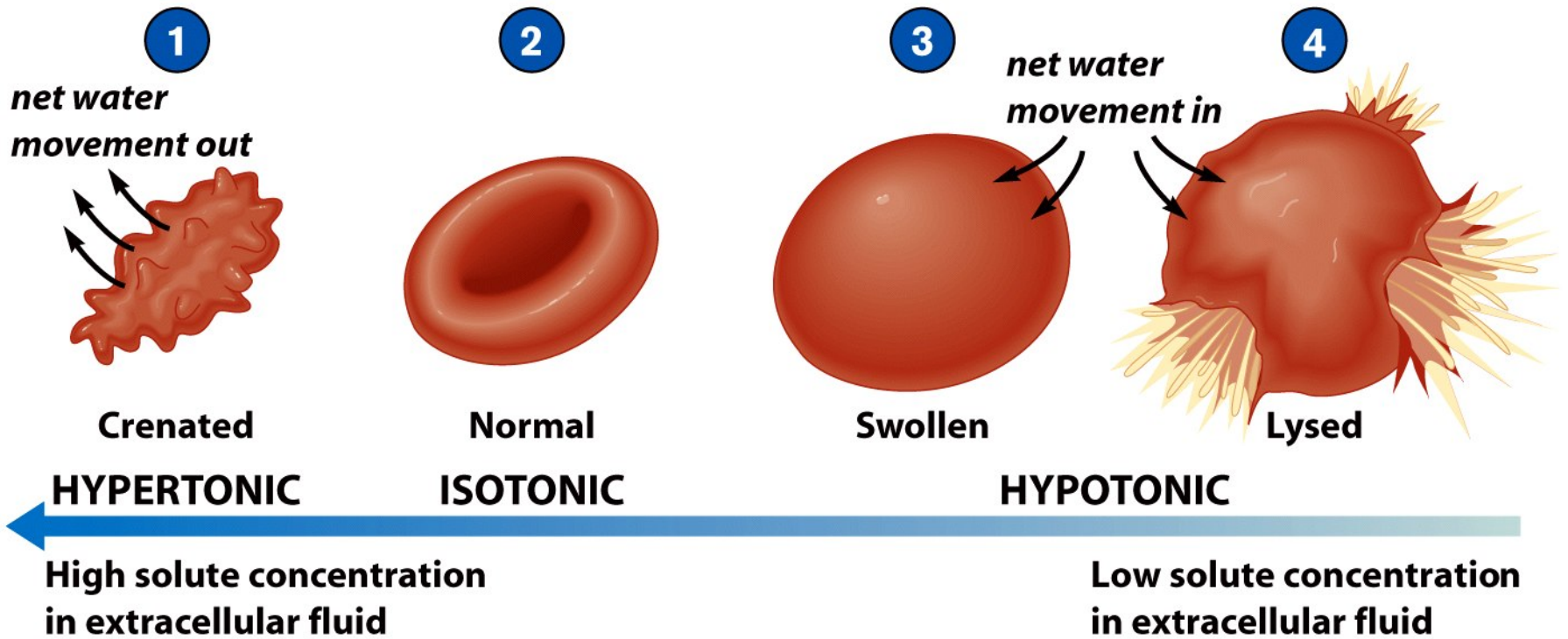

Facilitated Diffusion

- Differentially permeable membrane
- Channels (are specific) help molecule or ions enter or leave the cell
- Channels usually are transport proteins (aquaporins facilitate the movement of water)
- No energy is used

Process of Facilitated Transport

- Protein binds with molecule
- Shape of protein changes
- Molecule moves across membrane

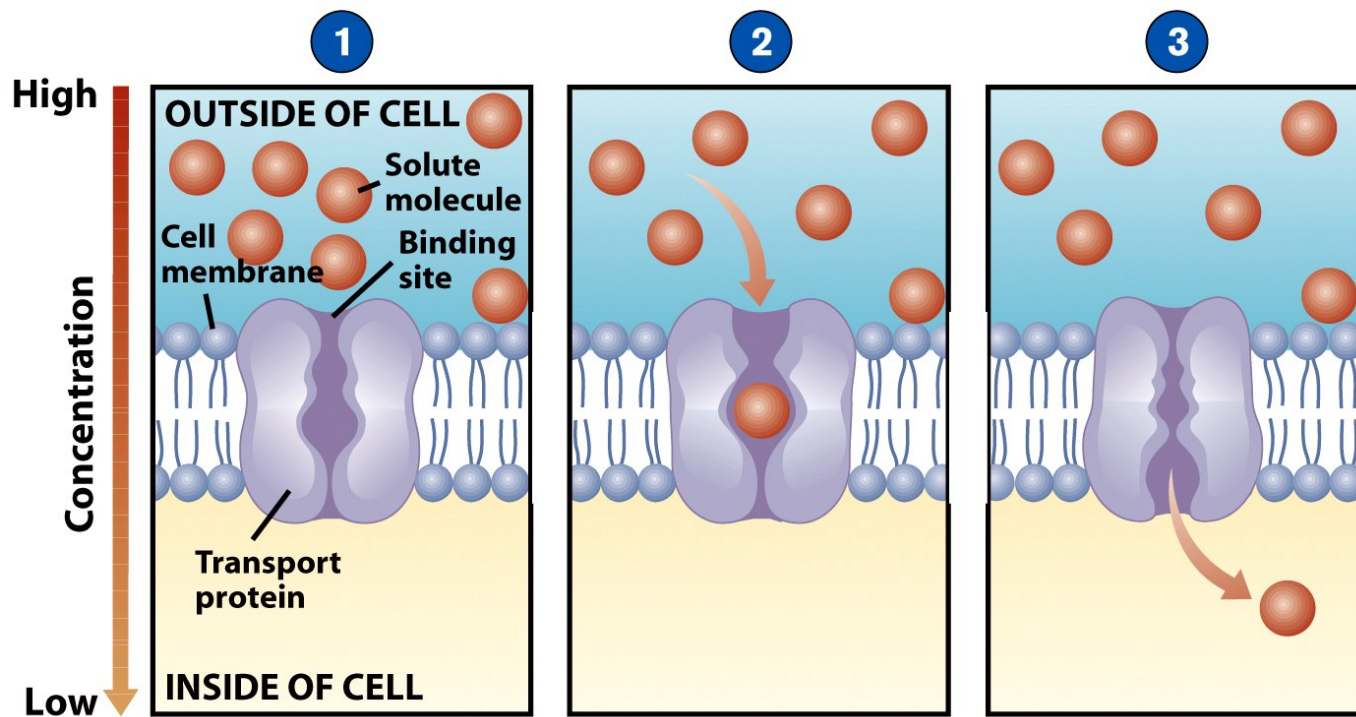

Active Transport

- Molecular movement
- Requires energy (against gradient)
- Example is sodium-potassium pump

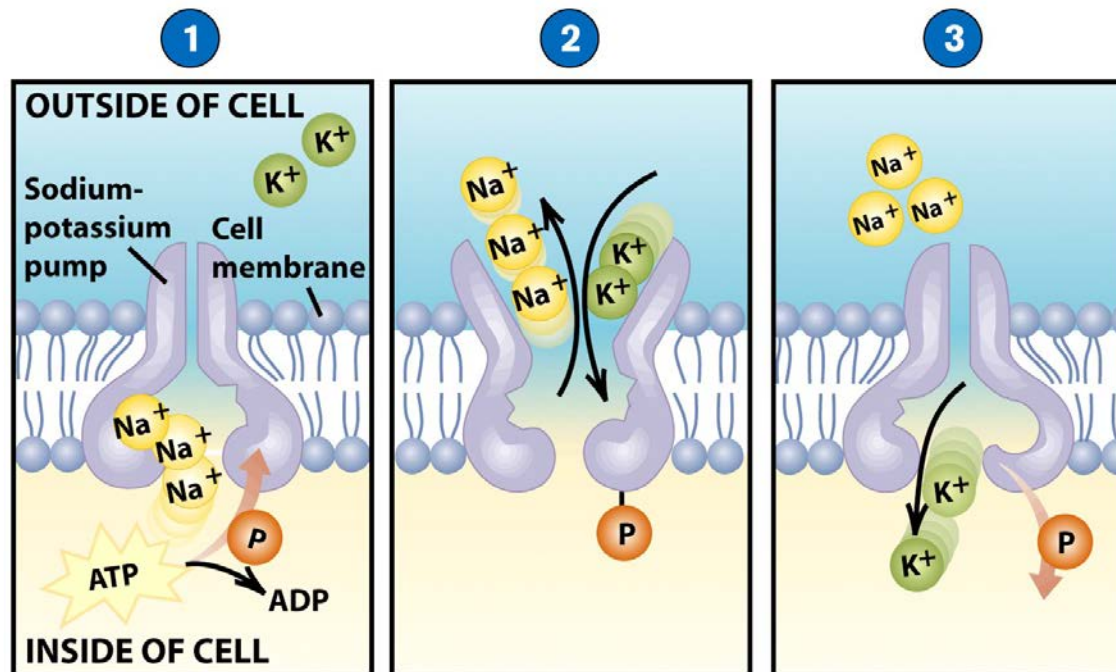

Endocytosis

- Movement of large material
 - Particles
 - Organisms
 - Large molecules
- Movement is into cells
- Types of endocytosis
 - bulk-phase (nonspecific)
 - receptor-mediated (specific)

Process of Endocytosis

- Plasma membrane surrounds material
- Edges of membrane meet
- Membranes fuse to form vesicle

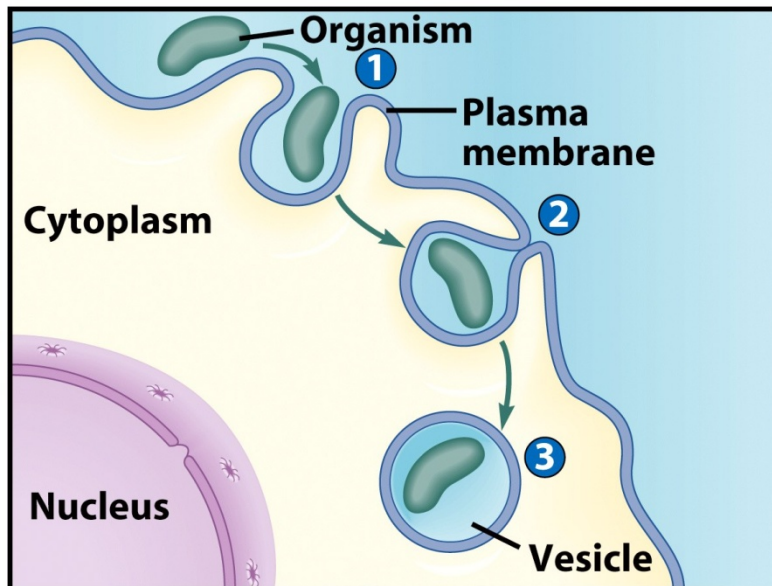

PHAGOCYTOSIS

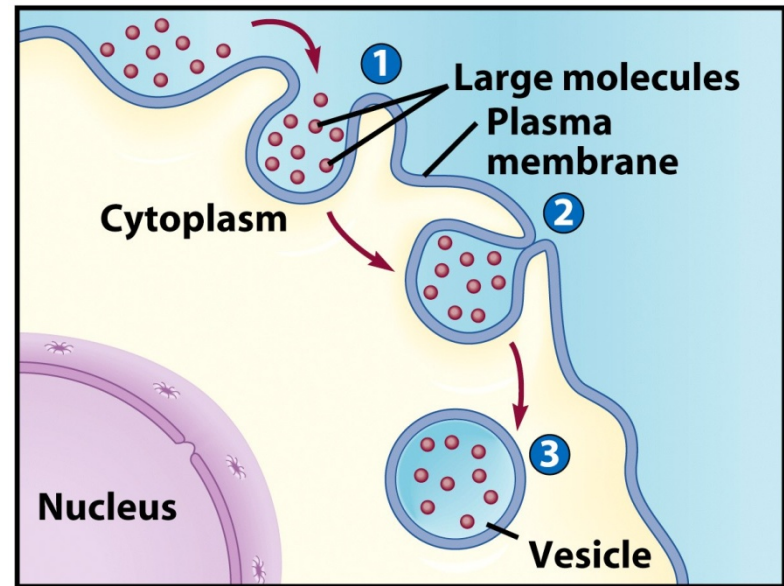

PINOCYTOSIS

Forms of Endocytosis

- Phagocytosis – cell eating
- Pinocytosis – cell drinking

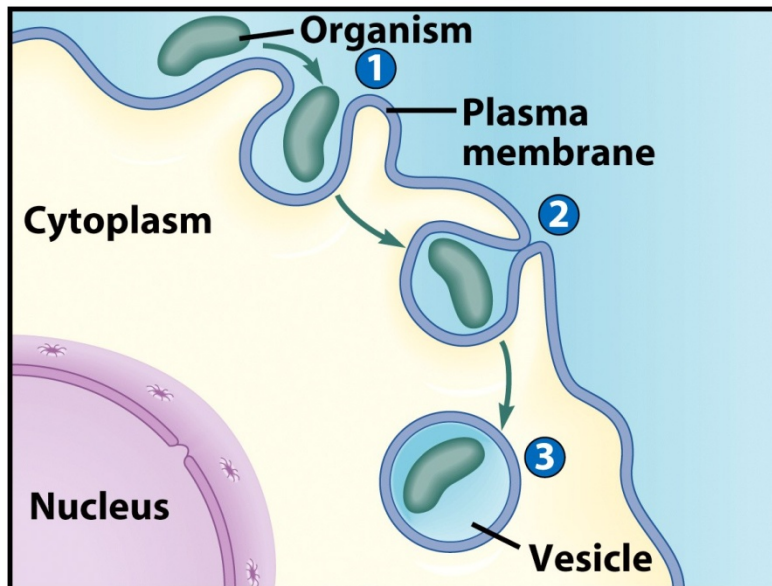

PHAGOCYTOSIS

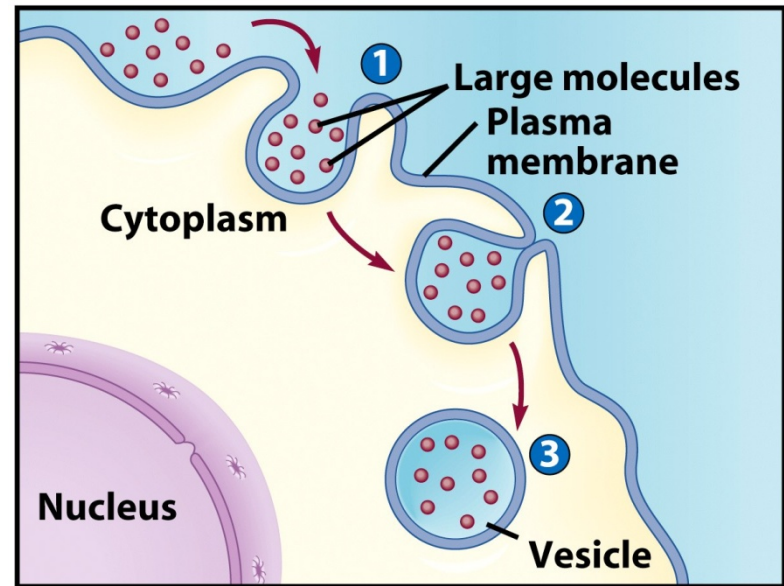

PINOCYTOSIS

Exocytosis

- Reverse of endocytosis
- Cell discharges material

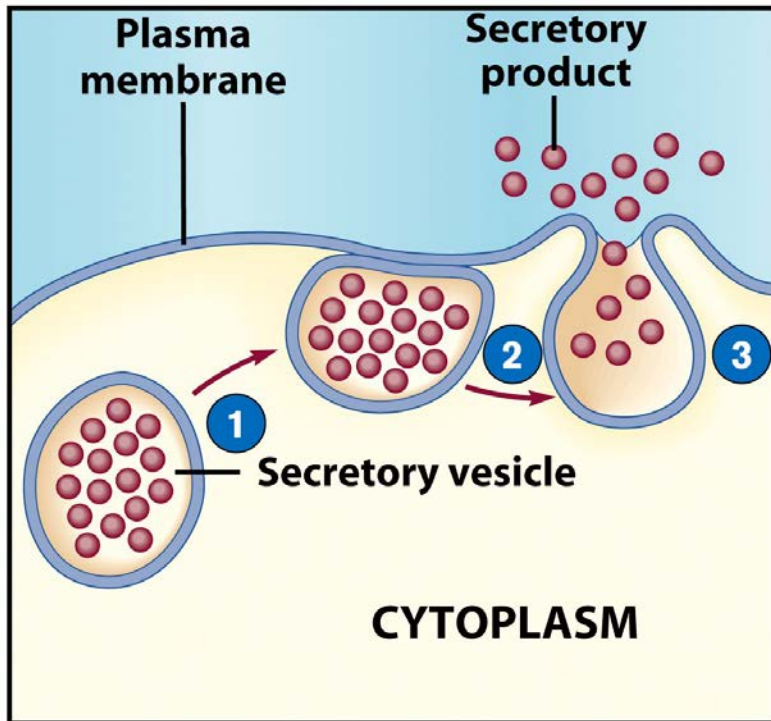

Exocytosis

- Vesicle moves to cell surface
- Membrane of vesicle fuses
- Materials expelled

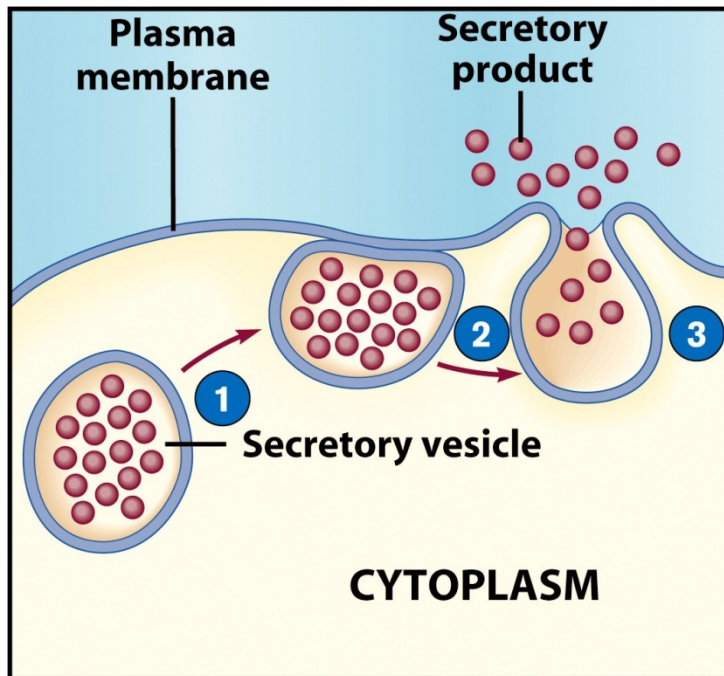

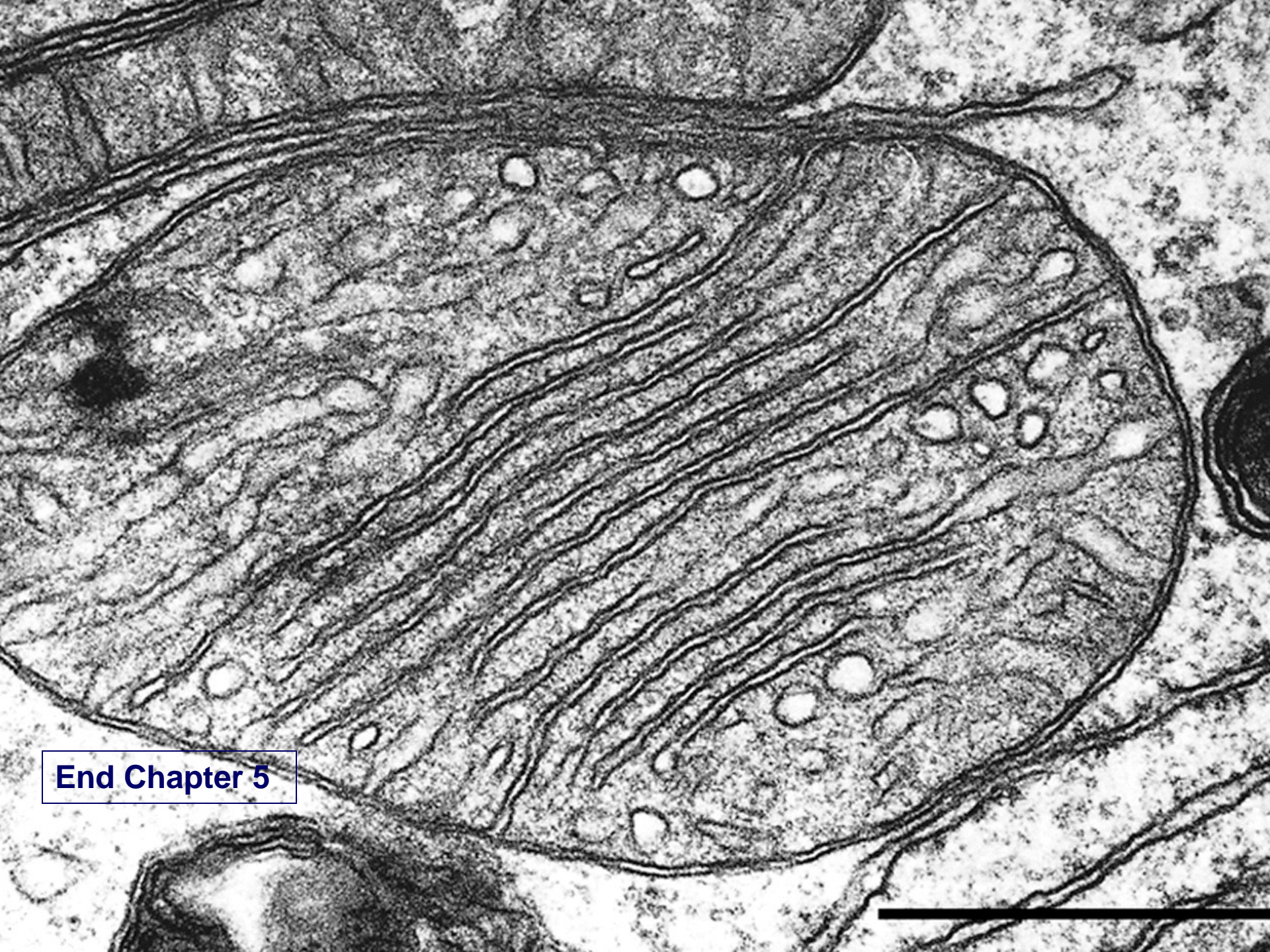

End Chapter 5